**Implants for surgery — Wear of total
intervertebral spinal disc prostheses —**

Part 1:

**Loading and displacement parameters for
wear testing and corresponding
environmental conditions for test**

*Implants chirurgicaux — Usure des prothèses totales de remplacement
des disques intervertébraux lombaires —*

*Partie 1: Paramètres de charge et de déplacement pour essais d'usure
et conditions environnementales correspondantes*



Reference number
ISO 18192-1:2008(E)

© ISO 2008

PDF disclaimer

This PDF file may contain embedded typefaces. In accordance with Adobe's licensing policy, this file may be printed or viewed but shall not be edited unless the typefaces which are embedded are licensed to and installed on the computer performing the editing. In downloading this file, parties accept therein the responsibility of not infringing Adobe's licensing policy. The ISO Central Secretariat accepts no liability in this area.

Adobe is a trademark of Adobe Systems Incorporated.

Details of the software products used to create this PDF file can be found in the General Info relative to the file; the PDF-creation parameters were optimized for printing. Every care has been taken to ensure that the file is suitable for use by ISO member bodies. In the unlikely event that a problem relating to it is found, please inform the Central Secretariat at the address given below.



COPYRIGHT PROTECTED DOCUMENT

© ISO 2008

All rights reserved. Unless otherwise specified, no part of this publication may be reproduced or utilized in any form or by any means, electronic or mechanical, including photocopying and microfilm, without permission in writing from either ISO at the address below or ISO's member body in the country of the requester.

ISO copyright office
Case postale 56 • CH-1211 Geneva 20
Tel. + 41 22 749 01 11
Fax + 41 22 749 09 47
E-mail copyright@iso.org
Web www.iso.org

Published in Switzerland

Contents

Page

Foreword.....	iv
1 Scope	1
2 Normative references	1
3 Terms and definitions	1
4 Principle.....	2
5 Reagents and materials	3
5.1 Fluid test medium	3
5.2 Test and control specimen	3
6 Apparatus	4
6.1 Testing machine.....	4
6.2 Means of mounting and enclosing the test specimen.....	7
6.3 Means of aligning and positioning.....	7
6.4 Motion control system	8
6.5 Force control system	8
6.6 Lubrication system	8
6.7 Temperature control system	8
6.8 Control station(s).....	8
7 Procedure	8
8 Test report	9
9 Disposal of test specimen	10
Annex A (informative) Statement of rationale for test methods.....	11
Annex B (informative) Load and displacement data for cervical implants	12
Annex C (informative) Load and displacement data for lumbar implants.....	13
Annex D (informative) Alternative loading conditions	14
Bibliography	25

Foreword

ISO (the International Organization for Standardization) is a worldwide federation of national standards bodies (ISO member bodies). The work of preparing International Standards is normally carried out through ISO technical committees. Each member body interested in a subject for which a technical committee has been established has the right to be represented on that committee. International organizations, governmental and non-governmental, in liaison with ISO, also take part in the work. ISO collaborates closely with the International Electrotechnical Commission (IEC) on all matters of electrotechnical standardization.

International Standards are drafted in accordance with the rules given in the ISO/IEC Directives, Part 2.

The main task of technical committees is to prepare International Standards. Draft International Standards adopted by the technical committees are circulated to the member bodies for voting. Publication as an International Standard requires approval by at least 75 % of the member bodies casting a vote.

Attention is drawn to the possibility that some of the elements of this document may be the subject of patent rights. ISO shall not be held responsible for identifying any or all such patent rights.

ISO 18192-1 was prepared by Technical Committee ISO/TC 150, *Implants for surgery*, Subcommittee SC 5, *Osteosynthesis and spinal devices*.

ISO 18192 consists of the following parts, under the general title *Implants for surgery — Wear of total intervertebral spinal disc prostheses*:

- *Part 1: Loading and displacement parameters for wear testing and corresponding environmental conditions for test*

Implants for surgery — Wear of total intervertebral spinal disc prostheses —

Part 1: Loading and displacement parameters for wear testing and corresponding environmental conditions for test

1 Scope

This part of ISO 18192 defines a test procedure for the relative angular movement between articulating components, and specifies the pattern of the applied force, speed and duration of testing, sample configuration and test environment to be used for the wear testing of total intervertebral spinal disc prostheses.

Both lumbar and cervical prostheses are addressed. This part of ISO 18192 does not address partial disc replacements, such as nucleus replacements or facet joint replacements. The test method focuses on wear testing. Additional mechanical tests such as fatigue testing can be required.

This part of ISO 18192 does not reproduce the complex *in vivo* loads and motions. The wear data obtained with this test method will enable comparison between different types of implants but can differ from the clinical wear performance. The user of this part of ISO 18192 should consider running additional wear tests addressing specific safety issues of the individual implant design to be tested.

2 Normative references

The following referenced documents are indispensable for the application of this document. For dated references, only the edition cited applies. For undated references, the latest edition of the referenced document (including any amendments) applies.

ISO 14242-2, *Implants for surgery — Wear of total hip-joint prostheses — Part 2: Methods of measurement*

3 Terms and definitions

For the purposes of this document, the following terms and definitions apply.

3.1

axial rotation

angular movement in the transverse plane around the z -axis

NOTE See Figure 1 c).

3.2

flexion/extension

angular movement in the sagittal plane around the y -axis

NOTE See Figure 1 a).

3.3 functional failure
failure that renders the implant unable to resist the load and/or move as initially intended by the design of the implant

3.4 lateral bending
angular movement in the frontal plane around the x -axis

NOTE See Figure 1 b).

3.5 mechanical failure
onset of a defect in the material

EXAMPLE Initiation of fatigue crack.

3.6 origin
centre of the coordinate system located at the instantaneous centre of rotation at the neutral position of the total disc replacement

NOTE The nominal centre is specified by the design.

3.7 user defined failure
any failure criterion that is established and controlled by the user considering the specific design of the implant to be tested

3.8 x -axis
positive x -axis directed anteriorly

NOTE See Figure 1.

3.9 y -axis
positive y -axis directed laterally to the left

NOTE See Figure 1.

3.10 z -axis
positive z -axis directed superiorly

NOTE See Figure 1.

4 Principle

The inferior and superior components of a test specimen are placed in position in the configuration intended for clinical use. The test apparatus transmits a specified time-varying force between the components, together with specified relative angular displacements. A load soak control specimen, if polymers are the object of investigation, is subjected to the same time-varying force to determine the creep of the test specimen and/or the amount of mass change due to fluid transfer. The test takes place in a controlled environment simulating physiological conditions.

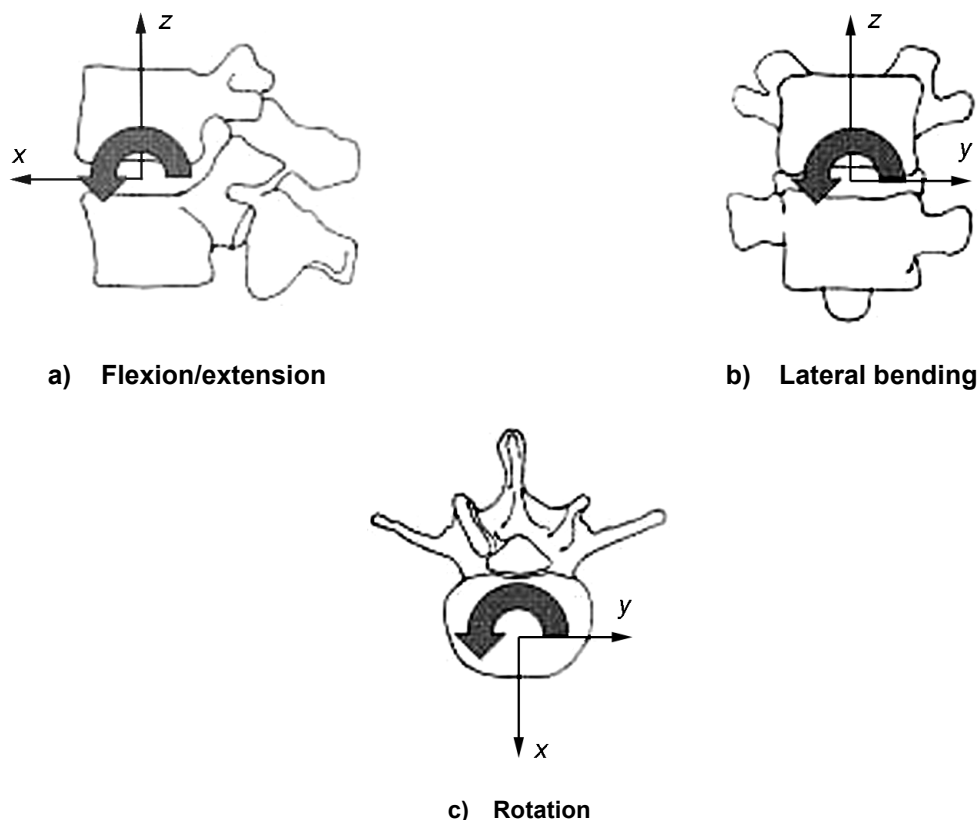

Figure 1 — Definition of the angular movements and coordinate axes

5 Reagents and materials

5.1 Fluid test medium

Calf serum diluted with de-ionized water (balance) to a concentration of $30 \text{ g} \pm 2 \text{ g}$ protein/l.

The fluid test medium may be filtered through a $2 \mu\text{m}$ filter if desired.

To minimize microbial contamination, the fluid test medium should be stored frozen until required for test. An anti-microbial reagent (such as sodium azide) may be added. Such reagents can be potentially hazardous.

The addition of 20 mmol/l EDTA solution may be used to bind calcium in solution and to minimize precipitation of calcium phosphate on to the bearing surfaces. The effect of EDTA will depend on the material combination tested. The addition of EDTA shall be justified by the user.

Routine monitoring of the pH of the fluid test medium should be undertaken. If it is, the values shall be included in the test report [see 8 k) 6)].

5.2 Test and control specimen

Between the inferior and superior components shall be the articulating surface of the inferior and superior components, attached by its normal immediate backing (for example, bone cement or a machined replica of the inner surface of the backing) unless this is impractical due to physical features of the implant system. If the component forming the articulating surface is fixed to the backing by a rim/snap-fit system, the machined replica shall provide the same fixation conditions.

If it is not practical to use the normal backing or cement fixation, due to physical features of the implant system, the support system for the inferior and/or superior component should represent normal design

features and conditions of use but should allow removal of the component for measurement of wear without destruction.

A recommended minimum sample number of six should be used for wear testing. If less than six specimens are tested, appropriate justification shall be given.

NOTE The number of specimens tested can be the subject of national legislation.

At least one additional sample shall be used to correct weight gain by fluid uptake (load soak control). The load soak control shall be loaded according to the load profile given for the type of implant. The user may decide not to use a soak control when testing materials that do not absorb surrounding fluid (for example, metal materials).

6 Apparatus

6.1 Testing machine, capable of producing the angular displacements specified in Table 1 and Figures 2 and 3 in association with the corresponding forces specified in Table 2 and operating at a frequency of $(1 \pm 0,1)$ Hz based on one cycle being the shortest repetitive interval for all motions and loads combined.

Table 1 — Angular displacements of the testing machine

	Angle	Flexion/extension	Axial rotation	Lateral bendings
Cervical	min.	- 7,5°	- 4°	- 6°
	max.	7,5	4°	6°
Lumbar	min.	- 3°	2°	2°
	max.	6°	- 2°	- 2°

NOTE The angular displacements indicated may be varied according to data given by the test requestor.

Table 2 — Load parameters of the testing machine

	Load (N)	
Cervical	max.	150
	min.	50
Lumbar	max.	2 000
	min.	600

NOTE The load parameters indicated may be varied according to data given by the test requestor.

A defined level of shear loading shall be implemented for lumbar implants being restrained in the transverse plane. Shear loading is achieved by inclining the implant with respect to the axial load axis in the sagittal plane at the reference position (see Figure 4). Certain designs can be sensitive to shear loads. The user may intensify the test conditions by increasing the shear load and/or adding alternating load directions.

NOTE 1 The user of this document should be aware that a certain amount of shear load is generated by the motion of the device with respect to the axial load. In regard to the implant design, the user should give a justification for intended physiological conditions, especially for motion of any articulating surfaces during the load and motion cycle.

NOTE 2 See Annex A for load and motion rationale.

All angular displacement curves and load curves are smooth. The curves shall reach the given values at 0 %, 25 %, 50 % and 75 % of the motion cycle within the tolerances given in 6.4. Sample data sets are provided in Annexes B and C.

The angles are referred to moving coordinate system.

The intended sequence of the angular transformation is: lateral bending – flexion/extension – axial rotation.

NOTE 3 The sequence of the axial rotations will slightly impact the motion and the final position after each motion step (Euler angles). Due to the small angles applied, Euler sequences differing from the above will result in almost identical relative motions. The Euler sequence chosen can be selected according to the mechanical set-up of the wear testing machine.

NOTE 4 The load curve is sinusoidal.

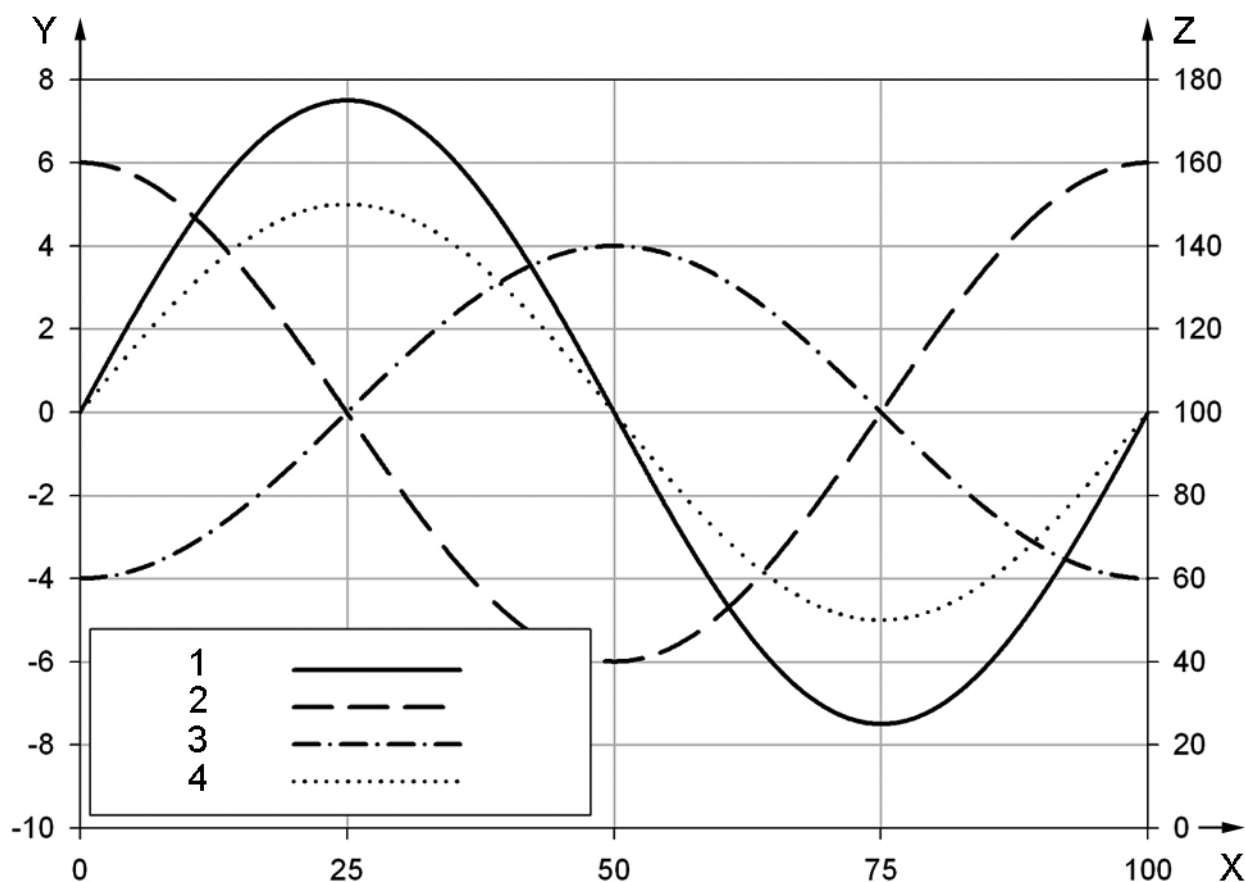

Key

- X cycle (%)
- Y angle (°)
- Z load (N)
- 1 flexion/extension
- 2 lateral bending
- 3 rotation
- 4 load

Figure 2 — Phasing of the displacement and load curves for cervical prostheses

The lateral bending is shifted 90° vs. the flexion extension axis;
the axial rotation and the lateral bending are 180° out of phase

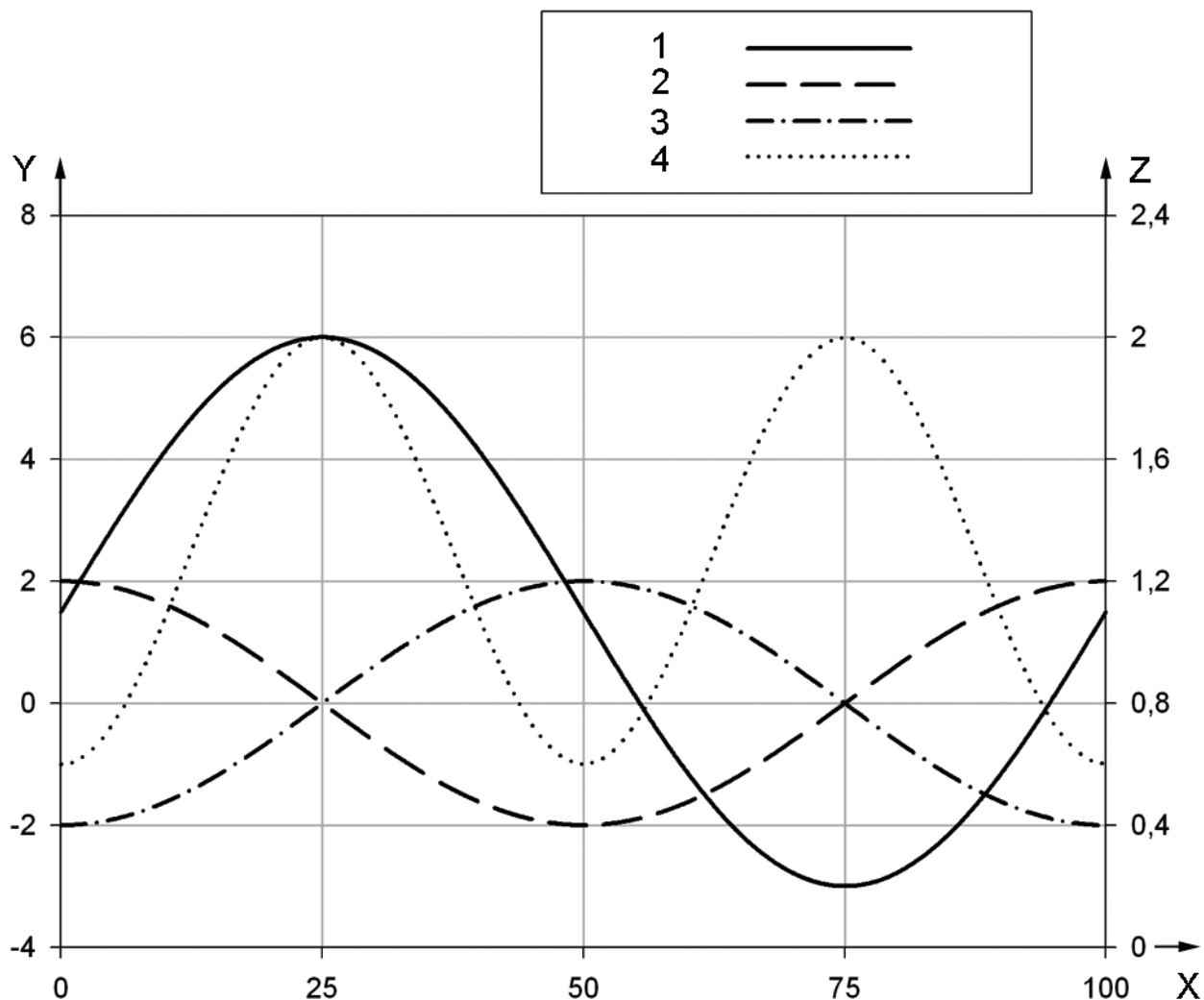

Key

- X cycle (%)
- Y angle (°)
- Z load (N)

- 1 flexion/extension
- 2 lateral bending
- 3 rotation
- 4 load

Figure 3 — Phasing of the displacement and load curves for lumbar prostheses

The lateral bending is shifted 90° vs. the flexion extension axis;
the axial rotation and the lateral bending are 180° out of phase.

6.2 Means of mounting and enclosing the test specimen, of a corrosion-resistant material, capable of holding inferior and superior components using attachment methods comparable to the intended anatomical fixation shall be used.

6.3 Means of aligning and positioning, to align the superior component of the test specimen in the superior position, so that its instantaneous axis of rotation at the neutral position is situated at the centre of the axes of rotation of the test machine and the same position and orientation can be reproduced following removal for measurement or cleaning, if required.

Align the inferior component of the test specimen, so that its instantaneous axis of rotation at the neutral position is situated at the centre of the axes of rotation of the test machine and the same position and orientation can be reproduced following removal for measurement. This alignment is intended to prevent preloads in the initial test position.

Incline the z-axis of lumbar implants 10° with respect to the load axis to generate enhanced shear (see Figure 4). The shear load is intended to act from posterior to anterior. Cervical implants are not inclined with respect to the axial load.

NOTE 1 Some designs using mobile bearings can generate less wear if the mobile bearing is forced by the shear load to remain in one position. In this case the user should use no inclination to generate worst case conditions.

NOTE 2 Shear forces will act on the device due to the cyclic inclination with respect to the axial load.

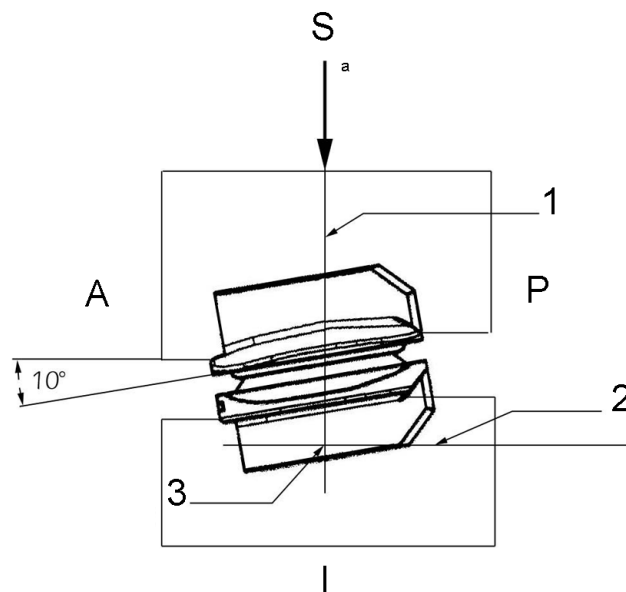

Key

- A anterior
- S superior
- P posterior
- I inferior
- 1 rotation axis
- 2 lateral bending axis
- 3 centre of rotation
- a axial force

Figure 4 — Inclination of the lumbar implant in the sagittal plane to simulate shear loading

6.4 Motion control system, capable of generating the angular movements of the superior component as given in Figures 2 and 3 with an accuracy of $\pm 0,5^\circ$ at the maxima and minima of the motion and $\pm 2\%$ of the full cycle time for phasing. For multi-station test systems, capabilities shall be assessed with all stations active.

6.5 Force control system, capable of generating a force in *z*-direction (see Figure 1) and which varies as shown in Figures 2 and 3, and capable of maintaining the magnitude of the maxima and minima of this force cycle to a tolerance of $\pm 5\%$ of the maximum force value for the cycle and $\pm 3\%$ of the full cycle time for phasing. For multi-station test systems, capabilities shall be assessed with all stations active.

6.6 Lubrication system, capable of maintaining the contact surfaces immersed in the fluid test medium.

NOTE The use of sealed enclosures can prevent evaporation and contamination.

6.7 Temperature control system, capable of maintaining the temperature of the fluid test medium (see 5.1) at $(37 \pm 2)^\circ\text{C}$.

6.8 Control station(s), capable of applying the loading regime shown in Figures 2 and 3 and incorporating the requirements given in 6.2, 6.3, 6.6 and 6.7.

7 Procedure

7.1 Clean the test specimen.

NOTE Cleaning of the test specimen can be carried out as described in ISO 14242-2 or by an alternative method.

7.2 Make any initial measurements which are required to determine the subsequent amount of wear and/or creep. Calibrate all test stations with a time-varying load to ensure the system load meets the requirements in 6.5. For multi-station test systems, perform calibration with all stations active.

NOTE Methods of measurement of wear are given in ISO 14242-2.

7.3 Mount the specimen in the testing machine.

7.4 Take the load soak control specimen and repeat steps in 7.1, 7.2 and 7.3.

7.5 Introduce fresh fluid test medium (see 5.1) to completely immerse the contact surfaces of the test specimen and the control specimen. Maintain the temperature of the fluid test medium at $(37 \pm 2)^\circ\text{C}$, taking the measurement at a location representative of the bulk temperature of the fluid. Determine the pH-value (optional).

7.6 Wait until the specimen has reached steady state temperature.

7.7 Start the testing machine and adjust it so that the loads and displacements specified in Figures 1 to 3 are applied to the test specimen (see 6.4 and 6.5). The curves between the defined maxima and minima in Figures 2 and 3 shall be smooth with no overshoots. Record the displacement and load waveforms at start-up, and after each change of fluid test medium for every single test station if independent test stations are used and for one test station if mechanically connected test stations are used.

7.8 Operate the testing machine at a frequency of 1 Hz with an accuracy of $\pm 0,1$ Hz. 1 Hz refers to one cycle per second where one cycle is defined as the shortest repetitive interval for all motions and loads combined. Test frequencies up to 2 Hz may be used. The impact of test frequencies higher than 1 Hz on the implant material behaviour as well as on the accuracy of the test machine shall be investigated by the user. Adequate justification shall be given by the user.

7.9 Replace the fluid lost by evaporation during the test at least daily, by adding de-ionized water. Replace the fluid test medium completely at least every 5×10^5 cycles, or every seven days, whichever is shorter.

7.10 Stop the test for measurements at at least 5×10^5 cycles, 1×10^6 cycles and at least every 1×10^6 cycles thereafter until the test is terminated (see 7.14).

7.11 Remove the test specimen, load soak control from the testing machine and clean the test specimens.

NOTE Cleaning of the test specimen can be carried out as described in ISO 14242-2 or by an alternative method.

7.12 Take wear measurements in accordance with ISO 14242-2.

Reinstall the test specimen and load soak control in the testing machine.

7.13 Repeat the steps given in 7.5 to 7.12 until the test is terminated (see 7.14).

7.14 Continue the test until one of the following occurs.

a) Completion of 10^7 cycles (see A.5);

NOTE 1 At the request of the submitter of the specimen, the test can be continued beyond this limit.

NOTE 2 The number of cycles tested can be the subject of national legislation.

b) Functional or user defined failure of the implant;

NOTE A mechanical failure might not necessitate termination of the test since this test method attempts to characterize the time dependent wear properties of the device.

c) Failure of the testing machine to maintain the force and displacement parameters within the given tolerances (see 6.5 and 6.6).

8 Test report

The test report shall include the following information:

- a) reference to this part of ISO 18192, i.e. ISO 18192-1:2007;
- b) the identity of the test specimens, as stated by the submitter of the specimens for test, including size, material, type and manufacturer;
- c) a description of the testing machine, including number of stations, type of systems used for generating motions and forces, range of motions and forces, type of systems used for measuring motions and forces, arrangement for mounting specimen (see 5.2), arrangement for lubrication of articulating surfaces, arrangement for temperature control and arrangement for the exclusion of contaminant particles;
- d) the test frequency including a justification if a higher frequency than 1 Hz has been used;
- e) the inclination angle of the device and a justification of the selection in regard to the motion of the articulating surfaces;
- f) the number of specimens and a justification if less than six specimens (excluding the soak specimen) have been tested;
- g) the addition or avoidance of EDTA and a justification for doing so;
- h) the addition or avoidance of an anti-microbial reagent and a justification for doing so;
- i) the selection of the nominal centre of rotation based on the implant design;

- j) whether control specimens were used and, if not, the reference to the tests from which the control data were taken;
- k) a statement of results, including:
 - 1) total number of cycles applied;
 - 2) reason for terminating the test if less than 10^7 cycles were applied;
 - 3) description of the surfaces of all components at which relative movement has occurred;
 - 4) description of the condition of the interfaces between subcomponents, if the components are of modular construction;
 - 5) description of the failure mode if failure occurred;
 - 6) pH values, if routine monitoring was undertaken (see 5.1);
- l) details of the method of measurement of wear and the results obtained (ISO 14242-2), namely:
 - 1) method of wear measurement (i.e. gravimetric or dimensional);
 - 2) change in mass for each measurement using the gravimetric method, or change in volume for each measurement using the dimensional method;
 - 3) both the mean wear rate (gravimetric or dimensional method) and a description of the method to determine the mean wear rate (non-linear approximation, least squares fit, etc.);
 - 4) descriptive statistics including standard deviation;
 - 5) graphic presentation of wear as a function of cycle count;
- m) any deviations made from the original test protocol including the corresponding rationale.

9 Disposal of test specimen

No part of the test specimen shall be used for clinical purposes after testing.

Annex A (informative)

Statement of rationale for test methods

A.1 At the time of publication of this part of ISO 18192, very little knowledge about the *in vivo*, daily living loading situation of spinal disc implants is available. The aim of this test method is to give a single set of motions and loading conditions until more data becomes available.

A.2 The choice of the test fluid has been based on current wear standards like ISO 14242-1 and ISO 14243-1. There is currently no information available indicating the composition of the fluid surrounding an artificial disc implant. The user can consider worst case scenarios for the specific implant material when selecting the appropriate test fluid.

A.3 The magnitude of the load and motion profiles is based on range of motion data published in the literature (see e.g., Bibliography [4] to [13]). Daily living activities are assumed to cover a certain percentage of the maximum range of motion with single events of higher loads and motions. The aim of the wear test method is to simulate average loading conditions rather than the extremes. Nevertheless, the user should consider running tests at maximum loads and deflections such as migration tests, impingement tests and fatigue tests.

A.4 The definition of shear loads has been limited to the anterior-posterior direction neglecting changes in load direction (see ISO 14630^[3] and ISO 14242-1^[1]). Generating the shear load by inclining the implant versus the axial load is accepted to be a simple method. The justification for doing so is to simplify the test set-up by avoiding additional force actuators. The user of this part of ISO 18192 can decide to set up a more complex load regime for implants that involve a safety risk under enhanced shear loading.

A.5 At the time of publication of this part of ISO 18192, very little knowledge about the *in vivo* number of cycles per year is available. 10^7 test cycles are assumed to incorporate a high safety factor compared to the clinical life time expected. Therefore the user of this document can decide to use a lower number of total cycles. Appropriate justification for doing so is required by this part of ISO 18192.

Annex B (informative)

Load and displacement data for cervical implants

Loading cycle (%)	Flexion/extension (°)	Lateral bending (°)	Rotation (°)	Load (N)	Loading cycle (%)	Flexion/extension (°)	Lateral bending (°)	Rotation (°)	Load (N)
0	0,000	6,000	- 4,000	100,0	50	0,000	- 6,000	4,000	100,0
1	0,471	5,988	- 3,992	103,1	51	- 0,471	- 5,988	3,992	96,9
2	0,940	5,953	- 3,968	106,3	52	- 0,940	- 5,953	3,968	93,7
3	1,405	5,894	- 3,929	109,4	53	- 1,405	- 5,894	3,929	90,6
4	1,865	5,811	- 3,874	112,4	54	- 1,865	- 5,811	3,874	87,6
5	2,318	5,706	- 3,804	115,5	55	- 2,318	- 5,706	3,804	84,5
6	2,761	5,579	- 3,719	118,4	56	- 2,761	- 5,579	3,719	81,6
7	3,193	5,429	- 3,619	121,3	57	- 3,193	- 5,429	3,619	78,7
8	3,613	5,258	- 3,505	124,1	58	- 3,613	- 5,258	3,505	75,9
9	4,019	5,066	- 3,377	126,8	59	- 4,019	- 5,066	3,377	73,2
10	4,408	4,854	- 3,236	129,4	60	- 4,408	- 4,854	3,236	70,6
11	4,781	4,623	- 3,082	131,9	61	- 4,781	- 4,623	3,082	68,1
12	5,134	4,374	- 2,916	134,2	62	- 5,134	- 4,374	2,916	65,8
13	5,467	4,107	- 2,738	136,4	63	- 5,467	- 4,107	2,738	63,6
14	5,779	3,825	- 2,550	138,5	64	- 5,779	- 3,825	2,550	61,5
15	6,068	3,527	- 2,351	140,5	65	- 6,068	- 3,527	2,351	59,5
16	6,332	3,215	- 2,143	142,2	66	- 6,332	- 3,215	2,143	57,8
17	6,572	2,891	- 1,927	143,8	67	- 6,572	- 2,891	1,927	56,2
18	6,786	2,555	- 1,703	145,2	68	- 6,786	- 2,555	1,703	54,8
19	6,973	2,209	- 1,472	146,5	69	- 6,973	- 2,209	1,472	53,5
20	7,133	1,854	- 1,236	147,6	70	- 7,133	- 1,854	1,236	52,4
21	7,264	1,492	- 0,995	148,4	71	- 7,264	- 1,492	0,995	51,6
22	7,367	1,124	- 0,750	149,1	72	- 7,367	- 1,124	0,750	50,9
23	7,441	0,752	- 0,501	149,6	73	- 7,441	- 0,752	0,501	50,4
24	7,485	0,377	- 0,251	149,9	74	- 7,485	- 0,377	0,251	50,1
25	7,500	0,000	0,000	150,0	75	- 7,500	0,000	0,000	50,0
26	7,485	- 0,377	0,251	149,9	76	- 7,485	0,377	- 0,251	50,1
27	7,441	- 0,752	0,501	149,6	77	- 7,441	0,752	- 0,501	50,4
28	7,367	- 1,124	0,750	149,1	78	- 7,367	1,124	- 0,750	50,9
29	7,264	- 1,492	0,995	148,4	79	- 7,264	1,492	- 0,995	51,6
30	7,133	- 1,854	1,236	147,6	80	- 7,133	1,854	- 1,236	52,4
31	6,973	- 2,209	1,472	146,5	81	- 6,973	2,209	- 1,472	53,5
32	6,786	- 2,555	1,703	145,2	82	- 6,786	2,555	- 1,703	54,8
33	6,572	- 2,891	1,927	143,8	83	- 6,572	2,891	- 1,927	56,2
34	6,332	- 3,215	2,143	142,2	84	- 6,332	3,215	- 2,143	57,8
35	6,068	- 3,527	2,351	140,5	85	- 6,068	3,527	- 2,351	59,5
36	5,779	- 3,825	2,550	138,5	86	- 5,779	3,825	- 2,550	61,5
37	5,467	- 4,107	2,738	136,4	87	- 5,467	4,107	- 2,738	63,6
38	5,134	- 4,374	2,916	134,2	88	- 5,134	4,374	- 2,916	65,8
39	4,781	- 4,623	3,082	131,9	89	- 4,781	4,623	- 3,082	68,1
40	4,408	- 4,854	3,236	129,4	90	- 4,408	4,854	- 3,236	70,6
41	4,019	- 5,066	3,377	126,8	91	- 4,019	5,066	- 3,377	73,2
42	3,613	- 5,258	3,505	124,1	92	- 3,613	5,258	- 3,505	75,9
43	3,193	- 5,429	3,619	121,3	93	- 3,193	5,429	- 3,619	78,7
44	2,761	- 5,579	3,719	118,4	94	- 2,761	5,579	- 3,719	81,6
45	2,318	- 5,706	3,804	115,5	95	- 2,318	5,706	- 3,804	84,5
46	1,865	- 5,811	3,874	112,4	96	- 1,865	5,811	- 3,874	87,6
47	1,405	- 5,894	3,929	109,4	97	- 1,405	5,894	- 3,929	90,6
48	0,940	- 5,953	3,968	106,3	98	- 0,940	5,953	- 3,968	93,7
49	0,471	- 5,988	3,992	103,1	99	- 0,471	5,988	- 3,992	96,9

NOTE 100 % loading cycle correspond to 1 s.

Annex C (informative)

Load and displacement data for lumbar implants

Loading cycle (%)	Flexion/extension (°)	Lateral bending (°)	Rotation (°)	Load (kN)	Loading cycle (%)	Flexion/extension (°)	Lateral bending (°)	Rotation (°)	Load (kN)
0	1,500	2,000	- 2,000	0,600	50	1,500	- 2,000	2,000	0,600
1	1,783	1,996	- 1,996	0,606	51	1,217	- 1,996	1,996	0,606
2	2,064	1,984	- 1,984	0,622	52	0,936	- 1,984	1,984	0,622
3	2,343	1,965	- 1,965	0,649	53	0,657	- 1,965	1,965	0,649
4	2,619	1,937	- 1,937	0,687	54	0,381	- 1,937	1,937	0,687
5	2,891	1,902	- 1,902	0,734	55	0,109	- 1,902	1,902	0,734
6	3,157	1,860	- 1,860	0,790	56	- 0,157	- 1,860	1,860	0,790
7	3,416	1,810	- 1,810	0,854	57	- 0,416	- 1,810	1,810	0,854
8	3,668	1,753	- 1,753	0,925	58	- 0,668	- 1,753	1,753	0,925
9	3,911	1,689	- 1,689	1,002	59	- 0,911	- 1,689	1,689	1,002
10	4,145	1,618	- 1,618	1,084	60	- 1,145	- 1,618	1,618	1,084
11	4,368	1,541	- 1,541	1,169	61	- 1,368	- 1,541	1,541	1,169
12	4,580	1,458	- 1,458	1,256	62	- 1,580	- 1,458	1,458	1,256
13	4,780	1,369	- 1,369	1,344	63	- 1,780	- 1,369	1,369	1,344
14	4,967	1,275	- 1,275	1,431	64	- 1,967	- 1,275	1,275	1,431
15	5,141	1,176	- 1,176	1,516	65	- 2,141	- 1,176	1,176	1,516
16	5,299	1,072	- 1,072	1,598	66	- 2,299	- 1,072	1,072	1,598
17	5,443	0,964	- 0,964	1,675	67	- 2,443	- 0,964	0,964	1,675
18	5,572	0,852	- 0,852	1,746	68	- 2,572	- 0,852	0,852	1,746
19	5,684	0,736	- 0,736	1,810	69	- 2,684	- 0,736	0,736	1,810
20	5,780	0,618	- 0,618	1,866	70	- 2,780	- 0,618	0,618	1,866
21	5,859	0,497	- 0,497	1,913	71	- 2,859	- 0,497	0,497	1,913
22	5,920	0,375	- 0,375	1,951	72	- 2,920	- 0,375	0,375	1,951
23	5,965	0,251	- 0,251	1,978	73	- 2,965	- 0,251	0,251	1,978
24	5,991	0,126	- 0,126	1,994	74	- 2,991	- 0,126	0,126	1,994
25	6,000	0,000	0,000	2,000	75	- 3,000	0,000	0,000	2,000
26	5,991	- 0,126	0,126	1,994	76	- 2,991	0,126	- 0,126	1,994
27	5,965	- 0,251	0,251	1,978	77	- 2,965	0,251	- 0,251	1,978
28	5,920	- 0,375	0,375	1,951	78	- 2,920	0,375	- 0,375	1,951
29	5,859	- 0,497	0,497	1,913	79	- 2,859	0,497	- 0,497	1,913
30	5,780	- 0,618	0,618	1,866	80	- 2,780	0,618	- 0,618	1,866
31	5,684	- 0,736	0,736	1,810	81	- 2,684	0,736	- 0,736	1,810
32	5,572	- 0,852	0,852	1,746	82	- 2,572	0,852	- 0,852	1,746
33	5,443	- 0,964	0,964	1,675	83	- 2,443	0,964	- 0,964	1,675
34	5,299	- 1,072	1,072	1,598	84	- 2,299	1,072	- 1,072	1,598
35	5,141	- 1,176	1,176	1,516	85	- 2,141	1,176	- 1,176	1,516
36	4,967	- 1,275	1,275	1,431	86	- 1,967	1,275	- 1,275	1,431
37	4,780	- 1,369	1,369	1,344	87	- 1,780	1,369	- 1,369	1,344
38	4,580	- 1,458	1,458	1,256	88	- 1,580	1,458	- 1,458	1,256
39	4,368	- 1,541	1,541	1,169	89	- 1,368	1,541	- 1,541	1,169
40	4,145	- 1,618	1,618	1,084	90	- 1,145	1,618	- 1,618	1,084
41	3,911	- 1,689	1,689	1,002	91	- 0,911	1,689	- 1,689	1,002
42	3,668	- 1,753	1,753	0,925	92	- 0,668	1,753	- 1,753	0,925
43	3,416	- 1,810	1,810	0,854	93	- 0,416	1,810	- 1,810	0,854
44	3,157	- 1,860	1,860	0,790	94	- 0,157	1,860	- 1,860	0,790
45	2,891	- 1,902	1,902	0,734	95	0,109	1,902	- 1,902	0,734
46	2,619	- 1,937	1,937	0,687	96	0,381	1,937	- 1,937	0,687
47	2,343	- 1,965	1,965	0,649	97	0,657	1,965	- 1,965	0,649
48	2,064	- 1,984	1,984	0,622	98	0,936	1,984	- 1,984	0,622
49	1,783	- 1,996	1,996	0,606	99	1,217	1,996	- 1,996	0,606

NOTE 100 % loading cycle correspond to 1 s.

Annex D (informative)

Alternative loading conditions

D.1 General

This test is not intended to replace the standard wear test as described in the main body of this document.

The user of this document can consider running an additional wear test using alternative loading conditions. A set of data is provided for this purpose. Using these data will result in three major differences compared to the regular loading conditions:

- the implant will pass the reference position (no deflection in either direction);
- there will be two stopping points within one cycle with no relative motion between the components;

NOTE The stopping points can affect the wear characteristics of certain material combinations due to breakdown of the lubrication film.

- the cervical waveform will have an increased compressive load in extension.

D.2 Alternative loading conditions for cervical implants

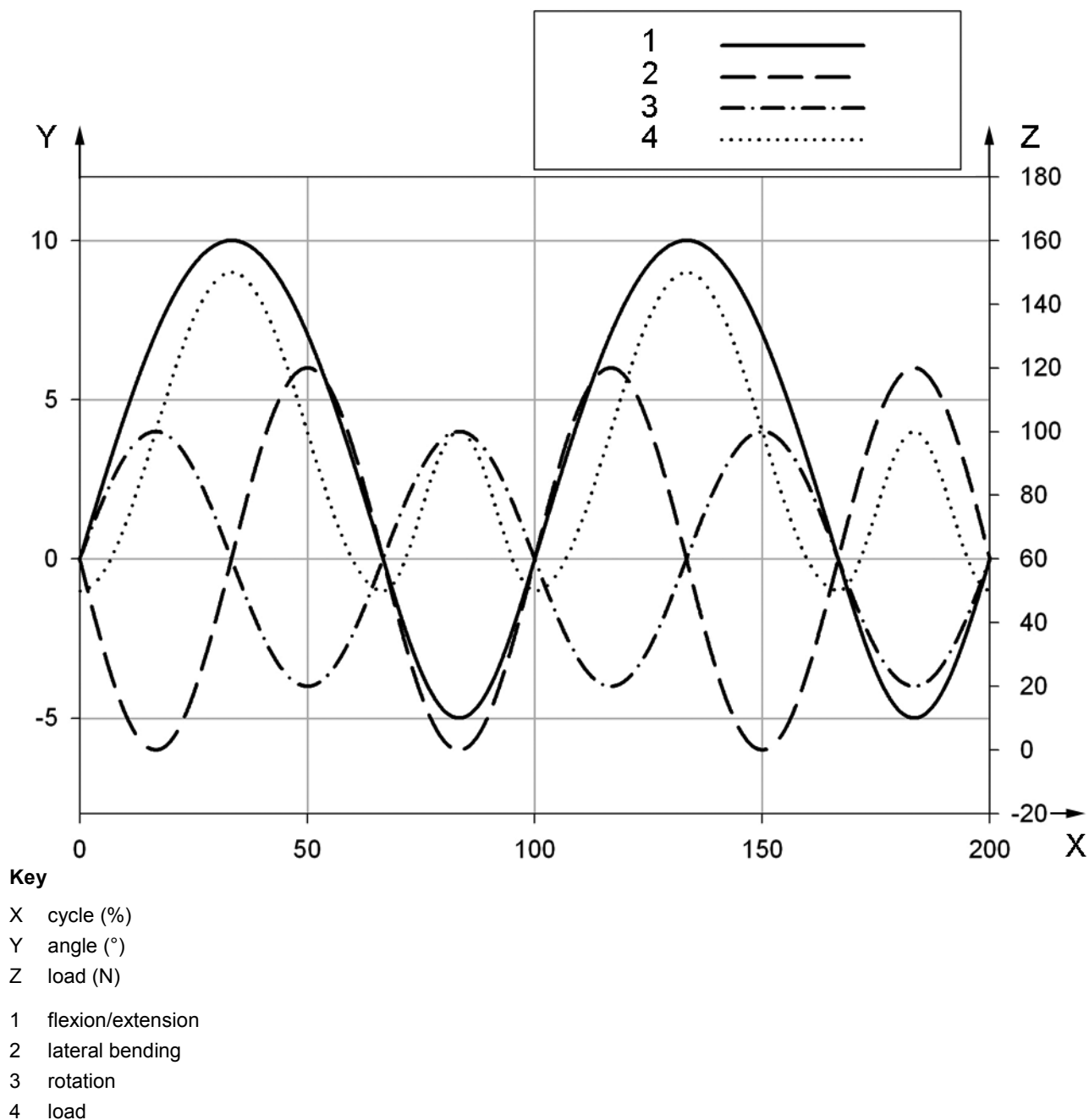

NOTE 100 % cycle corresponds to one cycle. The description of cycle given in 6.1 does not apply to Figure D.1.

Figure D.1 — Phasing of the displacement and load curves (alternative) for cervical prostheses

D.3 Alternative loading conditions for lumbar implants

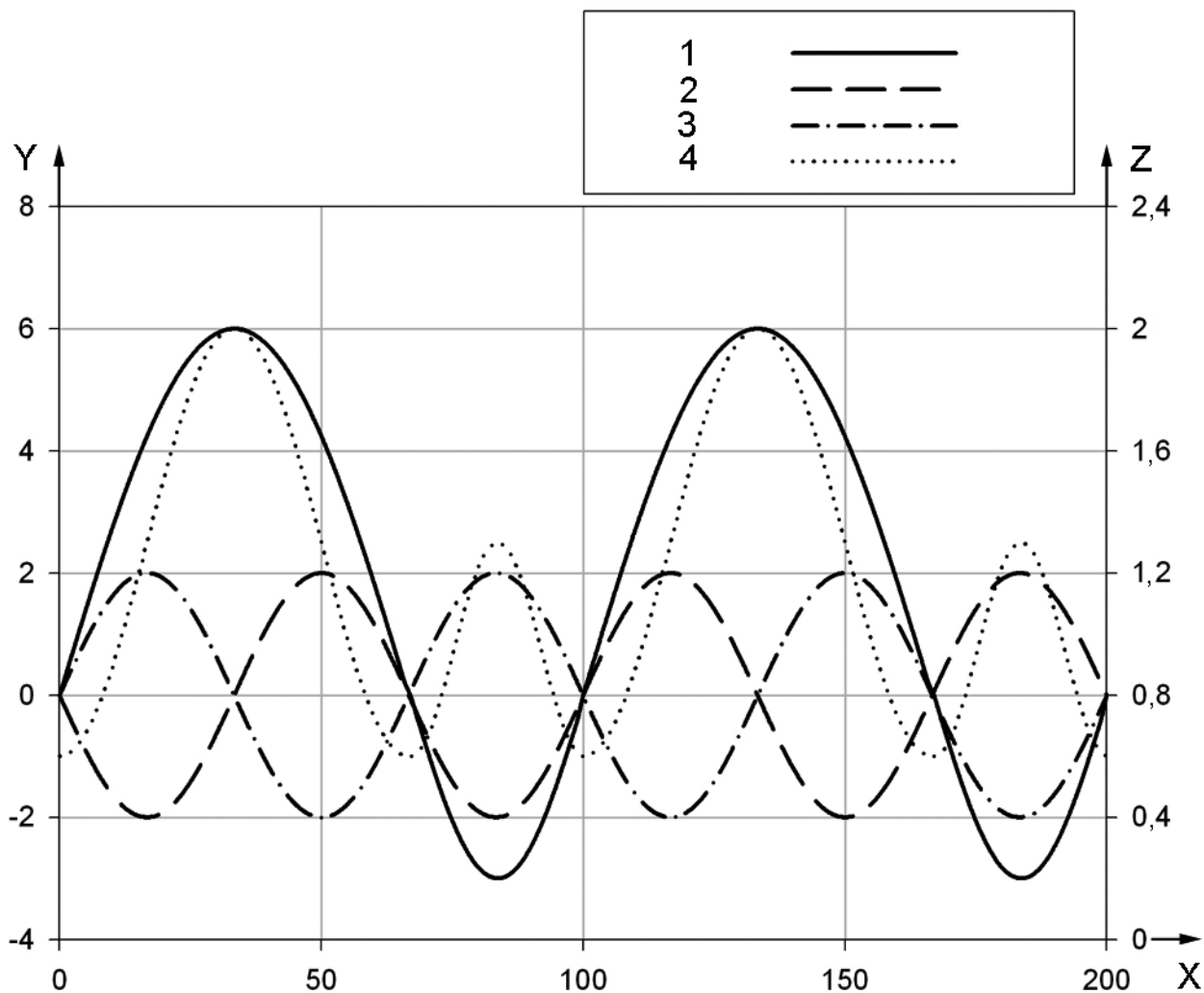

Key

- X cycle (%)
- Y angle (°)
- Z load (N)
- 1 flexion/extension
- 2 lateral bending
- 3 rotation
- 4 load

NOTE 100 % cycle corresponds to one cycle. The description of cycle given in 6.1 does not apply to Figure D.2.

Figure D.2 — Phasing of the displacement and load curves (alternative) for lumbar prostheses

D.4 Alternative load and displacement data for cervical implants

Table D.1 — Alternative load and displacement data for cervical implants

Loading cycle (%)	Flexion/extension (°)	Lateral bending (°)	Rotation (°)	Load (N)	Loading cycle (%)	Flexion/extension (°)	Lateral bending (°)	Rotation (°)	Load (N)
0	0,000	0,000	0,000	50,0	50	7,071	6,000	-4,000	100,0
1	0,471	-0,565	0,376	50,2	51	6,730	5,973	-3,982	95,3
2	0,941	-1,124	0,750	50,9	52	6,374	5,894	-3,929	90,6
3	1,409	-1,674	1,116	52,0	53	6,004	5,762	-3,841	86,1
4	1,874	-2,209	1,472	53,5	54	5,621	5,579	-3,719	81,6
5	2,334	-2,724	1,816	55,4	55	5,225	5,346	-3,564	77,3
6	2,790	-3,215	2,143	57,8	56	4,818	5,066	-3,377	73,2
7	3,239	-3,677	2,452	60,5	57	4,399	4,741	-3,161	69,4
8	3,681	-4,107	2,738	63,6	58	3,971	4,374	-2,916	65,8
9	4,115	-4,501	3,000	66,9	59	3,535	3,968	-2,645	62,5
10	4,540	-4,854	3,236	70,6	60	3,090	3,527	-2,351	59,5
11	4,955	-5,164	3,443	74,5	61	2,639	3,054	-2,036	57,0
12	5,358	-5,429	3,619	78,7	62	2,181	2,555	-1,703	54,8
13	5,750	-5,645	3,764	83,1	63	1,719	2,032	-1,355	53,0
14	6,129	-5,811	3,874	87,6	64	1,253	1,492	-0,995	51,6
15	6,494	-5,926	3,951	92,2	65	0,785	0,939	-0,626	50,6
16	6,845	-5,988	3,992	96,9	66	0,314	0,377	-0,251	50,1
17	7,181	-5,997	3,998	101,6	67	-0,157	-0,188	0,126	50,0
18	7,501	-5,953	3,968	106,3	68	-0,627	-0,752	0,501	50,8
19	7,804	-5,856	3,904	110,9	69	-1,091	-1,309	0,873	52,4
20	8,090	-5,706	3,804	115,5	70	-1,545	-1,854	1,236	54,8
21	8,358	-5,507	3,671	119,9	71	-1,986	-2,383	1,589	57,9
22	8,607	-5,258	3,505	124,1	72	-2,409	-2,891	1,927	61,6
23	8,838	-4,962	3,308	128,1	73	-2,810	-3,373	2,248	65,8
24	9,048	-4,623	3,082	131,9	74	-3,187	-3,825	2,550	70,3
25	9,239	-4,243	2,828	135,4	75	-3,536	-4,243	2,828	75,0
26	9,409	-3,825	2,550	138,5	76	-3,853	-4,623	3,082	79,7
27	9,558	-3,373	2,248	141,4	77	-4,135	-4,962	3,308	84,2
28	9,686	-2,891	1,927	143,8	78	-4,382	-5,258	3,505	88,4
29	9,792	-2,383	1,589	145,9	79	-4,589	-5,507	3,671	92,1
30	9,877	-1,854	1,236	147,6	80	-4,755	-5,706	3,804	95,2
31	9,940	-1,309	0,873	148,8	81	-4,880	-5,856	3,904	97,6
32	9,980	-0,752	0,501	149,6	82	-4,961	-5,953	3,968	99,2

Table D.1 (continued)

Loading cycle (%)	Flexion/extension (°)	Lateral bending (°)	Rotation (°)	Load (N)	Loading cycle (%)	Flexion/extension (°)	Lateral bending (°)	Rotation (°)	Load (N)
33	9,999	- 0,188	0,126	150,0	83	- 4,998	- 5,997	3,998	100,0
34	9,995	0,377	- 0,251	149,9	84	- 4,990	- 5,988	3,992	99,8
35	9,969	0,939	- 0,626	149,4	85	- 4,938	- 5,926	3,951	98,8
36	9,921	1,492	- 0,995	148,4	86	- 4,843	- 5,811	3,874	96,9
37	9,851	2,032	- 1,355	147,0	87	- 4,704	- 5,645	3,764	94,3
38	9,759	2,555	- 1,703	145,2	88	- 4,524	- 5,429	3,619	90,9
39	9,646	3,054	- 2,036	143,0	89	- 4,304	- 5,164	3,443	87,0
40	9,511	3,527	- 2,351	140,5	90	- 4,045	- 4,854	3,236	82,7
41	9,354	3,968	- 2,645	137,5	91	- 3,751	- 4,501	3,000	78,1
42	9,178	4,374	- 2,916	134,2	92	- 3,423	- 4,107	2,738	73,4
43	8,980	4,741	- 3,161	130,6	93	- 3,065	- 3,677	2,452	68,8
44	8,763	5,066	- 3,377	126,8	94	- 2,679	- 3,215	2,143	64,4
45	8,526	5,346	- 3,564	122,7	95	- 2,270	- 2,724	1,816	60,3
46	8,271	5,579	- 3,719	118,4	96	- 1,841	- 2,209	1,472	56,8
47	7,997	5,762	- 3,841	113,9	97	- 1,395	- 1,674	1,116	53,9
48	7,705	5,894	- 3,929	109,4	98	- 0,937	- 1,124	0,750	51,8
49	7,396	5,973	- 3,982	104,7	99	- 0,471	- 0,565	0,376	0,000
100	0,000	0,000	0,000	50,0	50,0	7,071	- 6,000	4,000	100,0
101	0,471	0,565	- 0,376	50,2	151	6,730	- 5,973	3,982	95,3
102	0,941	1,124	- 0,750	50,9	152	6,374	- 5,894	3,929	90,6
103	1,409	1,674	- 1,116	52,0	153	6,004	- 5,762	3,841	86,1
104	1,874	2,209	- 1,472	53,5	154	5,621	- 5,579	3,719	81,6
105	2,334	2,724	- 1,816	55,4	155	5,225	- 5,346	3,564	77,3
106	2,790	3,215	- 2,143	57,8	156	4,818	- 5,066	3,377	73,2
107	3,239	3,677	- 2,452	60,5	157	4,399	- 4,741	3,161	69,4
108	3,681	4,107	- 2,738	63,6	158	3,971	- 4,374	2,916	65,8
109	4,115	4,501	- 3,000	66,9	159	3,535	- 3,968	2,645	62,5
110	4,540	4,854	- 3,236	70,6	160	3,090	- 3,527	2,351	59,5
111	4,955	5,164	- 3,443	74,5	161	2,639	- 3,054	2,036	57,0
112	5,358	5,429	- 3,619	78,7	162	2,181	- 2,555	1,703	54,8
113	5,750	5,645	- 3,764	83,1	163	1,719	- 2,032	1,355	53,0
114	6,129	5,811	- 3,874	87,6	164	1,253	- 1,492	0,995	51,6
115	6,494	5,926	- 3,951	92,2	165	0,785	- 0,939	0,626	50,6
116	6,845	5,988	- 3,992	96,9	166	0,314	- 0,377	0,251	50,1
117	7,181	5,997	- 3,998	101,6	167	- 0,157	0,188	- 0,126	50,0

Table D.1 (continued)

Loading cycle (%)	Flexion/extension (°)	Lateral bending (°)	Rotation (°)	Load (N)	Loading cycle (%)	Flexion/extension (°)	Lateral bending (°)	Rotation (°)	Load (N)
118	7,501	5,953	- 3,968	106,3	168	- 0,627	0,752	- 0,501	50,8
119	7,804	5,856	- 3,904	110,9	169	- 1,091	1,309	- 0,873	52,4
120	8,090	5,706	- 3,804	115,5	170	- 1,545	1,854	- 1,236	54,8
121	8,358	5,507	- 3,671	119,9	171	- 1,986	2,383	- 1,589	57,9
122	8,607	5,258	- 3,505	124,1	172	- 2,409	2,891	- 1,927	61,6
123	8,838	4,962	- 3,308	128,1	173	- 2,810	3,373	- 2,248	65,8
124	9,048	4,623	- 3,082	131,9	174	- 3,187	3,825	- 2,550	70,3
125	9,239	4,243	- 2,828	135,4	175	- 3,536	4,243	- 2,828	75,0
126	9,409	3,825	- 2,550	138,5	176	- 3,853	4,623	- 3,082	79,7
127	9,558	3,373	- 2,248	141,4	177	- 4,135	4,962	- 3,308	84,2
128	9,686	2,891	- 1,927	143,8	178	- 4,382	5,258	- 3,505	88,4
129	9,792	2,383	- 1,589	145,9	179	- 4,589	5,507	- 3,671	92,1
130	9,877	1,854	- 1,236	147,6	180	- 4,755	5,706	- 3,804	95,2
131	9,940	1,309	- 0,873	148,8	181	- 4,880	5,856	- 3,904	97,6
132	9,980	0,752	- 0,501	149,6	182	- 4,961	5,953	- 3,968	99,2
133	9,999	0,188	- 0,126	150,0	183	- 4,998	5,997	- 3,998	100,0
134	9,995	- 0,377	0,251	149,9	184	- 4,990	5,988	- 3,992	99,8
135	9,969	- 0,939	0,626	149,4	185	- 4,938	5,926	- 3,951	98,8
136	9,921	- 1,492	0,995	148,4	186	- 4,843	5,811	- 3,874	96,9
137	9,851	- 2,032	1,355	147,0	187	- 4,704	5,645	- 3,764	94,3
138	9,759	- 2,555	1,703	145,2	188	- 4,524	5,429	- 3,619	90,9
139	9,646	- 3,054	2,036	143,0	189	- 4,304	5,164	- 3,443	87,0
140	9,511	- 3,527	2,351	140,5	190	- 4,045	4,854	- 3,236	82,7
141	9,354	- 3,968	2,645	137,5	191	- 3,751	4,501	- 3,000	78,1
142	9,178	- 4,374	2,916	134,2	192	- 3,423	4,107	- 2,738	73,4
143	8,980	- 4,741	3,161	130,6	193	- 3,065	3,677	- 2,452	68,8
144	8,763	- 5,066	3,377	126,8	194	- 2,679	3,215	- 2,143	64,4
145	8,526	- 5,346	3,564	122,7	195	- 2,270	2,724	- 1,816	60,3
146	8,271	- 5,579	3,719	118,4	196	- 1,841	2,209	- 1,472	56,8
147	7,997	- 5,762	3,841	113,9	197	- 1,395	1,674	- 1,116	53,9
148	7,705	- 5,894	3,929	109,4	198	- 0,937	1,124	- 0,750	51,8
149	7,396	- 5,973	3,982	104,7	199	- 0,471	0,565	- 0,376	50,4

NOTE 100 % loading cycle correspond to 1 s.

D.5 Alternative load and displacement data for lumbar implants

Table D.2 — Alternative load and displacement data for lumbar implants

Loading cycle (%)	Flexion/extension (°)	Lateral bending (°)	Rotation (°)	Load (kN)	Loading cycle (%)	Flexion/extension (°)	Lateral bending (°)	Rotation (°)	Load (kN)
0	0,000	0,000	0,000	0,600	50	4,243	2,000	-2,000	1,300
1	0,283	-0,188	0,188	0,603	51	4,038	1,991	-1,991	1,234
2	0,565	-0,375	0,375	0,612	52	3,825	1,965	-1,965	1,169
3	0,845	-0,558	0,558	0,628	53	3,603	1,921	-1,921	1,105
4	1,124	-0,736	0,736	0,649	54	3,373	1,860	-1,860	1,042
5	1,401	-0,908	0,908	0,676	55	3,135	1,782	-1,782	0,982
6	1,674	-1,072	1,072	0,709	56	2,891	1,689	-1,689	0,925
7	1,944	-1,226	1,226	0,747	57	2,640	1,580	-1,580	0,871
8	2,209	-1,369	1,369	0,790	58	2,383	1,458	-1,458	0,821
9	2,469	-1,500	1,500	0,837	59	2,121	1,323	-1,323	0,775
10	2,724	-1,618	1,618	0,889	60	1,854	1,176	-1,176	0,734
11	2,973	-1,721	1,721	0,944	61	1,583	1,018	-1,018	0,697
12	3,215	-1,810	1,810	1,002	62	1,309	0,852	-0,852	0,667
13	3,450	-1,882	1,882	1,063	63	1,032	0,677	-0,677	0,641
14	3,677	-1,937	1,937	1,126	64	0,752	0,497	-0,497	0,622
15	3,897	-1,975	1,975	1,190	65	0,471	0,313	-0,313	0,609
16	4,107	-1,996	1,996	1,256	66	0,188	0,126	-0,126	0,601
17	4,309	-1,999	1,999	1,322	67	0,000	-0,063	0,063	0,600
18	4,501	-1,984	1,984	1,388	68	-0,282	-0,251	0,251	0,606
19	4,683	-1,952	1,952	1,453	69	-0,562	-0,436	0,436	0,625
20	4,854	-1,902	1,902	1,516	70	-0,837	-0,618	0,618	0,654
21	5,015	-1,836	1,836	1,578	71	-1,104	-0,794	0,794	0,695
22	5,164	-1,753	1,753	1,637	72	-1,362	-0,964	0,964	0,744
23	5,303	-1,654	1,654	1,693	73	-1,607	-1,124	1,124	0,801
24	5,429	-1,541	1,541	1,746	74	-1,839	-1,275	1,275	0,863
25	5,543	-1,414	1,414	1,795	75	-2,054	-1,414	1,414	0,928
26	5,645	-1,275	1,275	1,839	76	-2,250	-1,541	1,541	0,994
27	5,735	-1,124	1,124	1,879	77	-2,427	-1,654	1,654	1,058
28	5,811	-0,964	0,964	1,913	78	-2,582	-1,753	1,753	1,119
29	5,875	-0,794	0,794	1,942	79	-2,714	-1,836	1,836	1,173
30	5,926	-0,618	0,618	1,966	80	-2,823	-1,902	1,902	1,220
31	5,964	-0,436	0,436	1,983	81	-2,906	-1,952	1,952	1,257
32	5,988	-0,251	0,251	1,994	82	-2,963	-1,984	1,984	1,283

Table D.2 (continued)

Loading cycle (%)	Flexion/extension (°)	Lateral bending (°)	Rotation (°)	Load (kN)	Loading cycle (%)	Flexion/extension (°)	Lateral bending (°)	Rotation (°)	Load (kN)
33	5,999	-0,063	0,063	2,000	83	-2,994	-1,999	1,999	1,297
34	5,997	0,126	-0,126	1,999	84	-2,999	-1,996	1,996	1,299
35	5,982	0,313	-0,313	1,991	85	-2,976	-1,975	1,975	1,289
36	5,953	0,497	-0,497	1,978	86	-2,928	-1,937	1,937	1,267
37	5,911	0,677	-0,677	1,959	87	-2,853	-1,882	1,882	1,233
38	5,856	0,852	-0,852	1,933	88	-2,753	-1,810	1,810	1,190
39	5,787	1,018	-1,018	1,903	89	-2,629	-1,721	1,721	1,138
40	5,706	1,176	-1,176	1,866	90	-2,481	-1,618	1,618	1,079
41	5,613	1,323	-1,323	1,825	91	-2,312	-1,500	1,500	1,016
42	5,507	1,458	-1,458	1,779	92	-2,121	-1,369	1,369	0,950
43	5,388	1,580	-1,580	1,729	93	-1,912	-1,226	1,226	0,884
44	5,258	1,689	-1,689	1,675	94	-1,686	-1,072	1,072	0,821
45	5,116	1,782	-1,782	1,618	95	-1,445	-0,908	0,908	0,762
46	4,962	1,860	-1,860	1,558	96	-1,191	-0,736	0,736	0,710
47	4,798	1,921	-1,921	1,495	97	-0,927	-0,558	0,558	0,667
48	4,623	1,965	-1,965	1,431	98	-0,654	-0,375	0,375	0,633
49	4,438	1,991	-1,991	1,366	99	-0,376	-0,188	0,188	0,611
100	0,000	0,000	0,000	0,600	150	4,243	-2,000	2,000	1,300
101	0,283	0,188	-0,188	0,603	151	4,038	-1,991	1,991	1,234
102	0,565	0,375	-0,375	0,612	152	3,825	-1,965	1,965	1,169
103	0,845	0,558	-0,558	0,628	153	3,603	-1,921	1,921	1,105
104	1,124	0,736	-0,736	0,649	154	3,373	-1,860	1,860	1,042
105	1,401	0,908	-0,908	0,676	155	3,135	-1,782	1,782	0,982
106	1,674	1,072	-1,072	0,709	156	2,891	-1,689	1,689	0,925
107	1,944	1,226	-1,226	0,747	157	2,640	-1,580	1,580	0,871
108	2,209	1,369	-1,369	0,790	158	2,383	-1,458	1,458	0,821
109	2,469	1,500	-1,500	0,837	159	2,121	-1,323	1,323	0,775
110	2,724	1,618	-1,618	0,889	160	1,854	-1,176	1,176	0,734
111	2,973	1,721	-1,721	0,944	161	1,583	-1,018	1,018	0,697
112	3,215	1,810	-1,810	1,002	162	1,309	-0,852	0,852	0,667
113	3,450	1,882	-1,882	1,063	163	1,032	-0,677	0,677	0,641
114	3,677	1,937	-1,937	1,126	164	0,752	-0,497	0,497	0,622
115	3,897	1,975	-1,975	1,190	165	0,471	-0,313	0,313	0,609
116	4,107	1,996	-1,996	1,256	166	0,188	-0,126	0,126	0,601
117	4,309	1,999	-1,999	1,322	167	0,000	0,063	-0,063	0,600

Table D.2 (continued)

Loading cycle (%)	Flexion/extension (°)	Lateral bending (°)	Rotation (°)	Load (kN)	Loading cycle (%)	Flexion/extension (°)	Lateral bending (°)	Rotation (°)	Load (kN)
118	4,501	1,984	- 1,984	1,388	168	- 0,282	0,251	- 0,251	0,606
119	4,683	1,952	- 1,952	1,453	169	- 0,562	0,436	- 0,436	0,625
120	4,854	1,902	- 1,902	1,516	170	- 0,837	0,618	- 0,618	0,654
121	5,015	1,836	- 1,836	1,578	171	- 1,104	0,794	- 0,794	0,695
122	5,164	1,753	- 1,753	1,637	172	- 1,362	0,964	- 0,964	0,744
123	5,303	1,654	- 1,654	1,693	173	- 1,607	1,124	- 1,124	0,801
124	5,429	1,541	- 1,541	1,746	174	- 1,839	1,275	- 1,275	0,863
125	5,543	1,414	- 1,414	1,795	175	- 2,054	1,414	- 1,414	0,928
126	5,645	1,275	- 1,275	1,839	176	- 2,250	1,541	- 1,541	0,994
127	5,735	1,124	- 1,124	1,879	177	- 2,427	1,654	- 1,654	1,058
128	5,811	0,964	- 0,964	1,913	178	- 2,582	1,753	- 1,753	1,119
129	5,875	0,794	- 0,794	1,942	179	- 2,714	1,836	- 1,836	1,173
130	5,926	0,618	- 0,618	1,966	180	- 2,823	1,902	- 1,902	1,220
131	5,964	0,436	- 0,436	1,983	181	- 2,906	1,952	- 1,952	1,257
132	5,988	0,251	- 0,251	1,994	182	- 2,963	1,984	- 1,984	1,283
133	5,999	0,063	- 0,063	2,000	183	- 2,994	1,999	- 1,999	1,297
134	5,997	- 0,126	0,126	1,999	184	- 2,999	1,996	- 1,996	1,299
135	5,982	- 0,313	0,313	1,991	185	- 2,976	1,975	- 1,975	1,289
136	5,953	- 0,497	0,497	1,978	186	- 2,928	1,937	- 1,937	1,267
137	5,911	- 0,677	0,677	1,959	187	- 2,853	1,882	- 1,882	1,233
138	5,856	- 0,852	0,852	1,933	188	- 2,753	1,810	- 1,810	1,190
139	5,787	- 1,018	1,018	1,903	189	- 2,629	1,721	- 1,721	1,138
140	5,706	- 1,176	1,176	1,866	190	- 2,481	1,618	- 1,618	1,079
141	5,613	- 1,323	1,323	1,825	191	- 2,312	1,500	- 1,500	1,016
142	5,507	- 1,458	1,458	1,779	192	- 2,121	1,369	- 1,369	0,950
143	5,388	- 1,580	1,580	1,729	193	- 1,912	1,226	- 1,226	0,884
144	5,258	- 1,689	1,689	1,675	194	- 1,686	1,072	- 1,072	0,821
145	5,116	- 1,782	1,782	1,618	195	- 1,445	0,908	- 0,908	0,762
146	4,962	- 1,860	1,860	1,558	196	- 1,191	0,736	- 0,736	0,710
147	4,798	- 1,921	1,921	1,495	197	- 0,927	0,558	- 0,558	0,667
148	4,623	- 1,965	1,965	1,431	198	- 0,654	0,375	- 0,375	0,633
149	4,438	- 1,991	1,991	1,366	199	- 0,376	0,188	- 0,188	0,611

NOTE 100 % loading cycle correspond to 1 s.

D.6 Cervical and lumbar alternative waveforms

Cervical and lumbar alternative waveforms are based on a general sine curve:

$$y = \text{offset} + \text{amplitude} \times \sin [(2 \pi / \text{period}) \times (t - \text{phase})]$$

The parameters defining the phasing and displacement curves for the cervical (C) prostheses using the alternative waveform are given in Table D.3.

Table D.3 — Parameters defining the phasing and displacement curves for cervical prostheses

Fraction of cycle (t)		$0 < t \leq 2/3$	$2/3 < t \leq 1$	$1 < t \leq 5/3$	$5/3 < t \leq 2$
Flexion-extension (°)	offset	0	0	0	0
	amplitude	10	5	10	5
	period	4/3	2/3	4/3	2/3
	phase	0	1/3	1	0
Compressive loading (N)	offset	100	75	100	75
	amplitude	50	25	50	25
	period	2/3	1/3	2/3	1/3
	phase	1/6	1/12	1/2	1/12
Lateral bending (°)	offset	0			
	amplitude	6			
	period	2/3			
	phase	1			
Axial rotation (°)	offset	0			
	amplitude	4			
	period	2/3			
	phase	0			

The parameters defining the phasing and displacement curves for the lumbar (L) prostheses using the alternative waveform are given in Table D.4.

Table D.4 — Parameters defining the phasing and displacement curves for lumbar prostheses

Fraction of cycle (<i>t</i>)		$0 < t \leq 2/3$	$2/3 < t \leq 1$	$1 < t \leq 5/3$	$5/3 < t \leq 2$
Flexion-Extension (°)	offset	0	0	0	0
	amplitude	6	3	6	3
	period	4/3	2/3	4/3	2/3
	phase	0	1/3	1	0
Compressive loading (N)	offset	1 300	950	1 300	950
	amplitude	700	350	700	350
	period	2/3	1/3	2/3	1/3
	phase	1/6	1/12	1/2	1/12
Lateral bending (°)	offset	0			
	amplitude	2			
	period	2/3			
	phase	1			
Axial rotation (°)	offset	0			
	amplitude	2			
	period	2/3			
	phase	0			

.....

Bibliography

- [1] ISO 14242-1, *Implants for surgery — Wear of total hip-joint prostheses — Part 1: Loading and displacement parameters for wear-testing machines and corresponding environmental conditions for test*
- [2] ISO 14243-1, *Implants for surgery — Wear of total knee-joint prostheses — Part 1: Loading and displacement parameters for wear-testing machines with load control and corresponding environmental conditions for test*
- [3] ISO 14630, *Non active surgical implants — General requirements*
- [4] PANJABI, M.M., DURANCEAUM, J., GOEL, V. et al., *Cervical human vertebrae: Quantitative three-dimensional anatomy of the middle and lower regions*, *Spine*, **16**(8), pp. 861-869, 1991
- [5] CALLAGHAN, J.P., PATLA, A.E. and MCGILL, S.M., *Low back three-dimensional joint forces, kinematics and kinetics during walking*, *Clin. Biomech.*, **14**, pp. 203-216, 1999
- [6] SNIJDERS, C.J., HOEK VAN DUKE, G.A. and ROOSCH, E.R., *A Biomechanical Model for the Analysis of the Cervical Spine in Static Postures*, *Journal of Biomechanics*, **24**(9), pp. 783-792, 1991
- [7] LUTTGENS, K. and HAMILTON, N., *Kinesiology: Scientific Basis of Human Motion*, 9th Edn., Brown & Benchmark, Madison, WI, 1997
- [8] KAPANDIJ, I.A., *Funktionelle Anatomie der Gelenke – Untere Extremität (Band 2)*, Ferdinand Enke Verlag, Stuttgart, 1985
- [9] PEARCY, M.J., PORTEK, J. and SHEPARD, J., *Three dimensional X-ray analysis of normal measurement in the lumbar spine*, *Spine*, **9**, pp. 294-300, 1984
- [10] PEARCY, M.J. and TIBREWAL, S.B., *Axial rotation and lateral bending in the normal lumbar spine measured by three-dimensional radiography*, *Spine*, **9**, pp. 582-587, 1984
- [11] WILKE, H.J., NEEF, P., CAIMI, M., HOOGLAND, T. and CLAES L.E., *New in vivo measurements of pressures in the intervertebral disc in daily life*, *Spine*, **24**(8), pp. 755-762, 1999
- [12] WHITE, A.A., and PANJABI, M.M., *Clinical Biomechanics of the spine*, p. 22., J.B. Lippincott, Philadelphia, 1978
- [13] PANJABI, M.M., CRISCO, J.J., VASAVADA, A. et al., *Mechanical properties of the human cervical spine as shown by three dimensional load displacement curves*, *Spine*, **26**(24), pp. 2692-2700, 2001
- [14] WIGFIELD, C., GILL, S., NELSON, R., LANGDON, I., METCALF, N. and ROBERTSON, J., *Influence of an artificial cervical joint compared with fusion on adjacent-level motion in the treatment of degenerative cervical disc disease*. *Journal of Neurosurgery*, **96**, pp. 17-21, 2002
- [15] NACHEMSON, A.L., *Disc pressure measurements*, *Spine*, **6**(1), pp. 93-97, 1981
- [16] SATO, K., KIKUCHI, S. and YONEZAWA, T., *In vivo intradiscal pressure measurement in healthy individuals and in patients with ongoing back problems*. *Spine*, **24**(23), pp. 2468-2474, 1999
- [17] CAPPOZZO, A., *Compressive loads in the lumbar vertical column during normal level walking*, *J. Orthop Res*, pp. 292-301, 1984

ICS 11.040.40

Price based on 25 pages