



Standard Test Method for Linearly Reciprocating Ball-on-Flat Sliding Wear¹

This standard is issued under the fixed designation G 133; the number immediately following the designation indicates the year of original adoption or, in the case of revision, the year of last revision. A number in parentheses indicates the year of last reapproval. A superscript epsilon (ϵ) indicates an editorial change since the last revision or reapproval.

1. Scope

1.1 This test method describes laboratory procedures for determining the sliding wear of ceramics, metals, and other candidate wear-resistant materials using a linear, reciprocating ball-on-flat plane geometry. The direction of the relative motion between sliding surfaces reverses in a periodic fashion such that the sliding occurs back and forth and in a straight line. The principal quantities of interest are the wear volumes of the contacting ball and flat specimen materials; however, the coefficient of kinetic friction may also be measured using the method described. This test method encompasses both unlubricated and lubricated testing procedures. The scope of this test method does not include testing in corrosive or chemically aggressive environments.

1.2 The values stated in SI units are to be regarded as the standard. The values given in parentheses are for information only.

1.3 *This standard does not purport to address all of the safety concerns, if any, associated with its use. It is the responsibility of the user of this standard to establish appropriate safety and health practices and determine the applicability of regulatory limitations prior to use.*

2. Referenced Documents

2.1 ASTM Standards:

- E 112 Test Methods for Determining Average Grain Size²
- E 1181 Test Methods for Characterizing Duplex Grain Sizes²
- G 40 Terminology Relating to Erosion and Wear³
- G 99 Test Method for Wear Testing with a Pin-on-Disk Apparatus³
- G 115 Guide for Measuring and Reporting Friction Coefficients³
- G 117 Guide for Calculating and Reporting Measures of Precision Using Data from Interlaboratory Wear or Erosion Tests³

¹ This test method is under the jurisdiction of ASTM Committee G02 on Wear and Erosion and is the direct responsibility of Subcommittee G02.40 on Non-Abrasive Wear.

Current edition approved Nov. 10, 2002. Published January 2003. Originally approved in 1995. Last previous edition approved in 2002 as G 133–95 (2002)¹.

² *Annual Book of ASTM Standards*, Vol 03.01.

³ *Annual Book of ASTM Standards*, Vol 03.02.

G 118 Guide for Recommended Format of Wear Test Data Suitable for Databases³

3. Terminology

3.1 *Definitions*—Definitions used in this test method are given in Terminology G 40. The following definitions of important terms used in this test method are cited from Terminology G 40.

3.1.1 *friction force*—the resisting force tangential to the interface between two bodies when, under the action of an external force, one body moves or tends to move relative to the other.

3.1.2 *Hertzian contact pressure*—the magnitude of the pressure at any specified location in a Hertzian contact area, as calculated from Hertz's equations of elastic deformation.

3.1.3 *wear*—damage to a solid surface, generally involving the progressive loss of material, due to relative motion between that surface and a contacting surface or surfaces.

3.1.4 *wear rate*—the rate of material removal or dimensional change due to wear per unit of exposure parameter, for example, quantity removed (mass, volume, thickness) in unit distance of sliding or unit time.

4. Summary of Test Method

4.1 This test method involves two specimens—a flat specimen and a spherically ended specimen (herein called the “ball” specimen) which slides against the flat specimen. These specimens move relative to one another in a linear, back and forth sliding motion, under a prescribed set of conditions.

4.2 In this test method, the load is applied vertically downward through the ball specimen against the horizontally mounted flat specimen. The normal load, stroke length, frequency and type of oscillation, test temperature, lubricant (if any), test duration, and atmospheric environment (including relative humidity range) are selected from one of two procedures.

4.3 Since this test method involves reciprocating sliding where changes in the sliding velocity and direction of motion occur during the test, constant velocity conditions are not maintained. The manner in which the velocity varies with time is determined by the design of the mechanism which drives the ball or flat specimen back and forth.

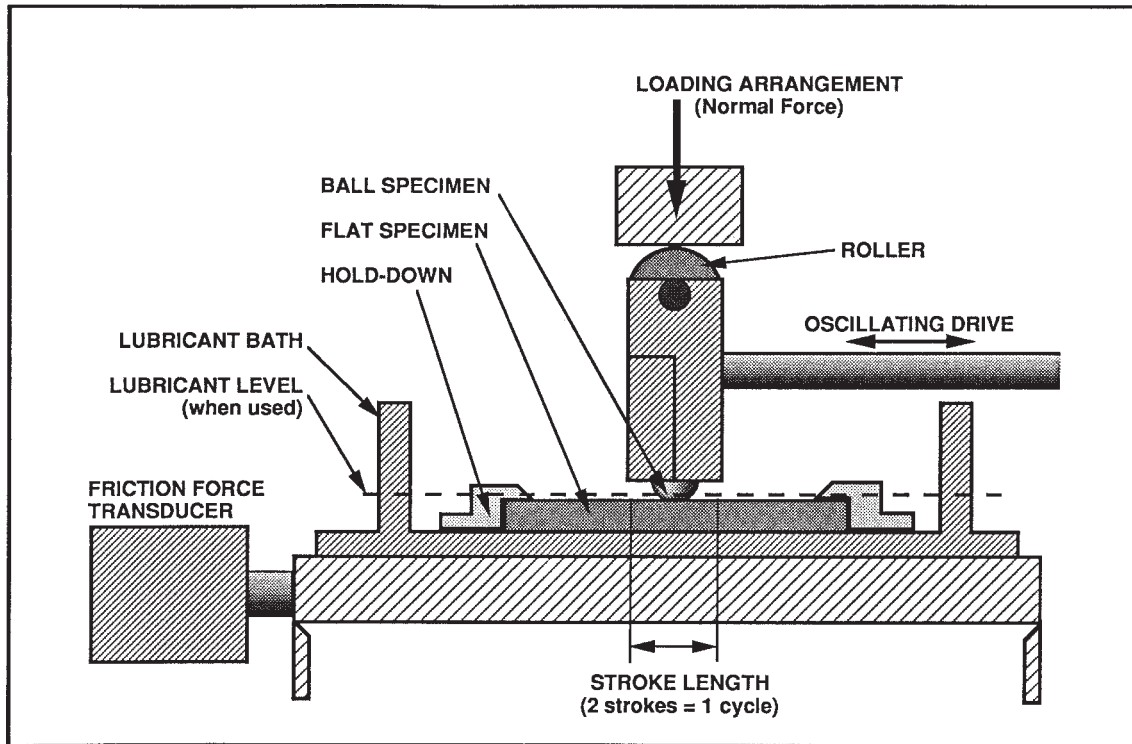

FIG. 1 Reciprocating Test—Schematic Diagram

4.4 Dimensional changes for both ball and flat specimens are used to calculate wear volumes and wear rates.

4.5 Friction forces are measured during the test and may be used to assess changes in the contact conditions or the kinetic friction coefficient as a function of time.

5. Significance and Use

5.1 This test method is designed to simulate the geometry and motions that are experienced in many types of rubbing components whose normal operation results in periodic reversals in the direction of relative sliding. The wear resulting from this mode of movement may differ from that experienced by the same materials sliding continuously in only one direction (unidirectional sliding) even for comparable durations of contact. Test loads and speeds are to be determined by the severity of the proposed application or purpose of the testing. Either of two sets of testing conditions (designated Procedures A and B) may be used.

6. Apparatus

6.1 *General Description*—Fig. 1 shows the arrangement for the reciprocating ball-on-flat wear test available on a commercial machine. The ball is rigidly mounted and has a spherical tip which moves back and forth across the surface of a polished flat specimen. Use of a spherical tip alleviates the alignment problems associated with flat-ended balls sliding on flat surfaces. Alternate configurations in which the flat moves and the ball specimen is fixed may be used. A provision is made for applying a uniform normal force (load) to the contact between the ball and the flat. Temperature measurement and control capability is provided to heat and monitor the flat specimen which may either be immersed in a lubricant bath or tested

without lubricant. The tangential force can be measured continuously during oscillating contact and used to obtain friction coefficient data.⁴

6.2 *Specimen Drive*—A drive train, capable of providing smooth, reciprocating motion to the ball and overcoming the frictional resistance of the specimens at maximum load, is required. For example, a Scotch yoke drive mechanism can provide a smooth, sinusoidal velocity profile for the ball specimen relative to the flat specimen without the need for the motor to stop and reverse direction periodically. Stepper-type motors may also be used provided that the motion is smooth and uniform.

6.3 *Ball and Ball Specimen Holder*—The ball specimen may be a fixed bearing ball or any spherically tipped specimen as long as the sliding contact is equivalent to a ball on a flat plane. If a bearing ball is used, it shall be clamped tightly enough to prevent slippage during the test. The ball holder should be rigid enough so that the periodic reversal in the sliding direction does not result in tilting or other misalignment of the contact.

6.4 *Flat Specimen Holder*—The flat specimen is secured to the base of the machine to prevent slippage or buckling during the test. A variety of shapes and configurations for the flat specimen are possible. The primary criterion is that the coupon present a flat, horizontal surface to the ball specimen.

6.5 Instrumentation:

6.5.1 *Friction Force*—A tension-compression load cell or similar force-sensing device may be used to measure the

⁴ Machines of this type are described in *A Catalogue of Friction and Wear Devices*, American Society of Lubrication Engineers (now STLE) 838 Busse Highway, Park Ridge, IL, 1973, pp. 50–72.

friction forces generated during sliding. Calibration of the friction force (see section 7.1.3) in both forward and reverse sliding directions is required. Since the direction of the friction force changes rapidly during the test, traditional strip-chart-type recorders may be too slow to follow these changes at high frequencies of reciprocation. A commercial version of this machine is available with a signal conditioner to rectify, and output the root-mean-square friction force to a strip-chart-recorder or to a computerized data acquisition system. The method of sensing and recording friction force during the test shall be described in the testing report.

6.5.2 *Test Duration*—In this test method, test duration is specified in seconds. To compute the sliding distance in metres or number of cycles, use the following:

$$X = 0.002 \times t \times f \times L \quad (1)$$

or

$$N = t \times f \quad (2)$$

where:

- X = total sliding distance of the ball, m,
- N = number of cycles in the test,
- t = test time, s,
- f = oscillating frequency, Hz (cycles/s), and
- L = length of stroke, mm.

A cycle is defined as two stroke lengths (up and back). Electronic timers can be used to terminate the test. If a cycle-counter is available, this may be used instead of the timer, in which case Eq 2 will be used.

6.5.3 *Humidity*—The wear and friction of many materials is significantly affected by the moisture in the air. It is therefore required that the relative humidity (to an accuracy of $\pm 3\%$) be measured before and during the test. Humidity can vary with air flow and in different parts of the same room, so the humidity sensor should be located as close to the test specimens as reasonably possible, in such a way that the air movement conditions are the same for humidity sensor as for the test specimens.

6.5.4 *Temperature*—The ambient temperature, in degrees Celsius, shall be measured and reported during room temperature tests. In full immersion, liquid-lubricated tests, the bath temperature shall be measured and reported.

7. Calibration

7.1 The parts of the apparatus that require calibration are (1) the loading system (2) the motion drive (speed and stroke length), and (3) the friction force sensor.

7.1.1 *Loading System*—The load (normal force) applied to the specimen shall be checked periodically. In machines which apply the load by a spring/lever arrangement and indicate the load on a dial gage, this can be done by substituting a previously calibrated compression load cell for the specimen and checking the applied load indicated on the loading dial against the calibrated load cell output. Statically applied loads shall be kept constant within a maximum deviation of $\pm 2.0\%$ of the test load. For example, permitted static error of a 25.0-N normal force would be ± 0.5 N. During oscillating tests, the normal force may vary slightly about the mean value due to the dynamics of the machine. This variation is to be expected.

7.1.2 *Motion Drive*—The oscillating frequency of the moving specimen shall be checked periodically against the drive motor setting to ensure that the rate of oscillation is known. (**Warning**—Due to inertial effects, differences in the loading and fixturing method become more significant as the oscillating frequency of the test is increased, and harmonic frequencies characteristic of the test machine must be avoided when selecting the oscillating frequency.)

7.1.3 *Friction Force Sensor*—The friction force sensor shall be calibrated periodically in both directions of load application. Depending on the machine, a fixture which applies a calibrating load in line with the normal point of contact between the ball and flat should be used.

8. Procedure

8.1 *Specimen Preparation*—The ball specimen and flat specimen shall be used either in a polished condition, or in a specified condition consistent with the application of interest. In a polished condition, the surface should be as free as possible from preparation artifacts such as grinding-induced cracks, gross grinding marks, and grain pull-out. Surface roughnesses of 0.02 to 0.05- μm R_a (arithmetic roughness) are typical.

8.2 Clean the specimens using the following procedure:

- 8.2.1 Wash with a mild liquid laboratory glassware cleaner,
- 8.2.2 Hot air dry,
- 8.2.3 Ultrasonically clean in acetone (2 min),
- 8.2.4 Hot air dry,
- 8.2.5 Ultrasonically clean in methanol (2 min), and
- 8.2.6 Hot air dry.

8.2.7 If there is considerable porosity in the specimens, it is necessary that they be baked dry for 4 h at a temperature greater than 150°C in a clean oven.

NOTE 1—Certain materials could be adversely affected by cleaning in solvents. Deviations from the prescribed cleaning procedure are permitted, but they shall be described in the report.

8.3 Clean the specimens after they are secured in place in the test fixture by wiping with acetone and then with methanol-moistened cotton swabs. It is possible that during mounting, some contamination was inadvertently placed on them, and this final cleaning will help alleviate the problem. Inspect the ball tip with a hand lens after it is mounted to ensure that there are no defects in the contact area.

8.4 Gently lower the ball specimen upon the flat specimen, and ensure that the reciprocating drive shaft motion is horizontal and parallel to the surface of the flat specimen. The height of the specimen or mount may require adjustment to ensure that this condition is fulfilled. Apply the prescribed test load. Confirm that the desired oscillating speed has been set before turning on the motor.

8.5 Two possible testing procedures, one for unlubricated tests (Procedure A), and one for high-contact stress-lubricated tests at elevated temperature (Procedure B), are given in 8.5.1. The procedure appropriate for the given materials and test severity should be selected. If neither procedure in 8.5.1 is determined to be suitable, other conditions may be used, but testing will not be in compliance with this test method. See the

reporting requirements in Section 10 for reporting exceptions to Procedures A and B.

8.5.1 The two testing procedures are as follows.

8.5.1.1 *Procedure A*—Unlubricated wear testing at room temperature.

- (a) (a) Pin tip radius, 4.76 mm ($\frac{3}{16}$ in.).
- (b) (b) Normal force, 25.0 N.
- (c) (c) Stroke length, 10.0 mm.
- (d) (d) Oscillating frequency, 5.0 Hz.
- (e) (e) Test duration, 16 min 40 s (sliding distance 100 m).
- (f) (f) Ambient temperature, $22 \pm 3^\circ\text{C}$.
- (g) (g) Relative humidity, 40 to 60 %.
- (h) (h) Lubrication, none applied.

8.5.1.2 *Procedure B*—Lubricated wear testing at elevated temperature.

- (a) (a) Pin tip radius, 4.76 mm ($\frac{3}{16}$ in.).
- (b) (b) Normal force, 200.0 N.
- (c) (c) Stroke length, 10.0 mm.
- (d) (d) Oscillating frequency, 10.0 Hz.
- (e) (e) Test duration, 33 min 20 s (sliding distance 400 m).
- (f) (f) Temperature, $150 \pm 2^\circ\text{C}$.
- (g) (g) Relative humidity, 40 to 60 %.
- (h) (h) Lubrication, full immersion under the selected lubricant (see Note 2).

NOTE 2—This procedure requires full-immersion lubrication. If other methods, such as a controlled drip feeding system, are used to simulate certain applications, the provisions of 8.6 will apply.

8.5.2 When heated, liquid-lubricated tests are being conducted, as in Procedure B, apply the lubricant and heat the specimens to the selected temperature allowing them to equilibrate for not less than 5 min before applying the load and starting the test. Bath temperature shall be controlled to within a maximum deviation of $\pm 2.0^\circ\text{C}$ from the desired temperature. A fresh supply of lubricant shall be used for each test unless the objective is to evaluate the effects of used lubricants on friction and wear.

8.5.3 Set the timer (or cycle counter), if available, for the selected test duration.

8.5.4 Start the friction (and temperature) recording equipment and initiate the test.

8.5.5 After the prescribed duration, stop the motor. Remove the normal force to recheck the *zero* point on the friction force recording system.

8.5.6 Allow specimens to cool, if heated, then remove the test specimens. To measure the wear, it is necessary to clean the specimens in such a way that the surface features are not altered. For unlubricated tests, a concentrated jet of air may be used to dispel the debris from the worn area of the specimens. For liquid-lubricated specimens, ultrasonic cleaning in a suitable solvent may be used. Specimens shall be thoroughly dried.

8.5.7 Examine the tip of the ball specimen to ensure that no rolling or other slippage has taken place. Any ball movement within the holder during the test invalidates the test results. Similarly, any slippage of the flat specimen in its fixture invalidates the test results.

8.6 *Alternative Testing Procedures*—To achieve certain simulation conditions, or for other technical reasons, Procedures A and B may not be suitable for a given reciprocating

wear testing project. Modifications to the specific test conditions prescribed in Procedures A and B may be used for conducting such tests; however, in reporting the results, the specific parameters which are not in compliance with one of the standard testing procedures shall be specifically noted. A statement such as the following may then be used: “These tests are not in full compliance with the provisions of Test Method G 133, Procedure A, because the normal force in these tests was 50.0 N, instead of 25.0 N as prescribed by the standard, and the stroke length was 5.0 mm, instead of 10.0 mm as prescribed by the standard. All other provisions of Test Method G 133 have been followed.”

9. Measurement and Calculation of Wear

9.1 Depending upon the relative wear of ball and flat specimens, various assumptions about the geometric irregularity of the wear scars can be made. Fig. 2 shows several possible wear conditions. In Fig. 2(a), the flat material is much more wear-resistant than the ball material. In Fig. 2(b), the ball material is much more wear-resistant than the flat material. In Fig. 2(c), measurable wear occurs on both ball and flat materials.

9.2 *Wear of the Ball Specimen*—Owing to the nature of this type of test, the wear scar on the ball specimen may not always be circular or flat. Refer to the following which applies.

9.2.1 If the end of the ball appears flat, but not circular, the average of the maximum and minimum dimensions of the scar shall be computed and this value used as the effective ball scar diameter (D). Pin scar measurements may be made by removing the ball specimen holder and placing the wear scar portion under a reflecting microscope. A calibrated ocular or a photomicrograph of known magnification may be used to measure scar dimensions.

9.2.1.1 The wear volume (V_p) for a flat ball wear scar of effective diameter D (the case in Fig. 2(a)), is found from the same relationship given in Test Method G 99, Appendix X1.1.1:

$$V_p = (\pi h/6)[3D^2/4 + h^2] \quad (3)$$

where:

h = height of material removed, mm.

Assuming a spherical wear volume, the height of material removed can be calculated from D as follows:

$$h = R - [R^2 - (D^2/4)]^{1/2} \quad (4)$$

where:

R = original ball radius, mm.

(Warning)—For lubricated tests in which there is minimal wear, it is possible to be misled in reading the apparent wear scar diameter of the ball tip optically because of elastic recovery. A small, shallow annulus surrounding the elastically deformed area may give the impression of wear, whereas little or no appreciable wear has actually occurred. Profilometry may be used to determine whether the wear scar is flat and consequently whether (Eq 3) and (Eq 4) can be used.)

9.2.2 If the ball tip is obviously worn, but the wear track profile on the flat specimen indicates that the ball is not entirely

View along the sliding direction (in and out of the plane of the figure) for three conditions of wear.

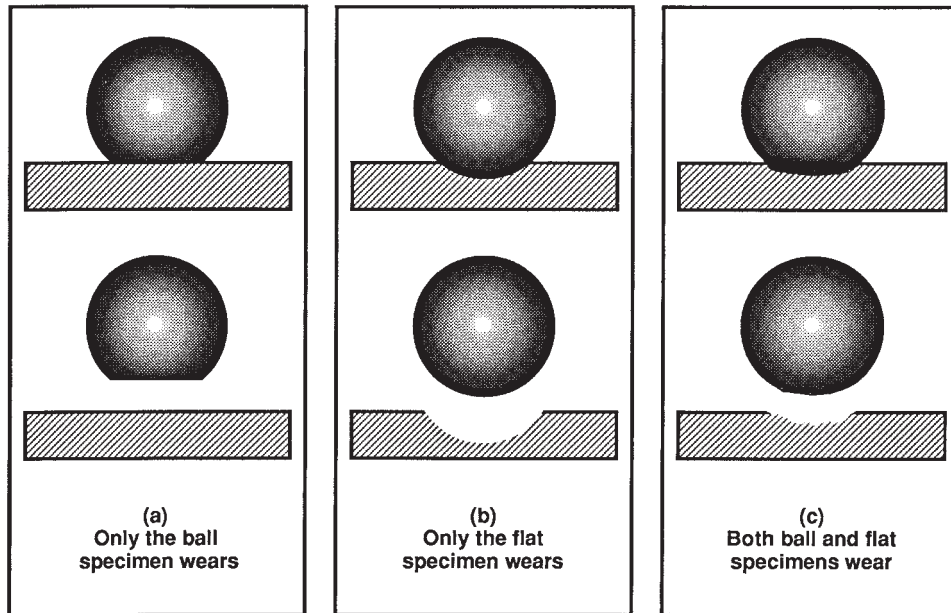

FIG. 2 Possible Situations for Differing Wear Resistance of Ball and Flat Specimens

flat, as in Fig. 2(c), note those facts and either measure volume by an alternate method, fully describing the method used, or do not report wear volume.

NOTE 3—Various methods have been used to measure the wear volumes of non-flat ball tips.⁵ These methods may be used and the results reported; however, a statement such as that given in 8.6 should be used to indicate that the calculation method is not in accordance with the provisions of this test method.

9.2.3 If there is only light abrasion or a few scratches on the ball specimen, the term “no measurable wear” may be used.

9.2.4 If the tip of the ball is obscured by an adherent deposit of wear debris, no measure of wear shall be reported, but the reason why the measurement cannot be made shall be reported.

9.3 *Wear of the Flat Specimen*—The wear volume of the flat specimen is computed from the length of the stroke and the average cross-sectional area of the wear track, as measured at locations equally spaced along its length. In most cases, the width and depth of the wear scar on the flat specimen will be relatively uniform throughout its length. If the areas of the three initial profiles differ by less than 25 %, three profiles will be sufficient. If wear is nonuniform, six cross-sectional profiles shall be obtained to compute the average track cross-sectional area. Generally, in calculating wear volume of the flat specimen, the minor geometric errors associated with the direction-reversal points at each end of the track can be neglected. (**Warning**—It is not recommended that continuous wear depth data obtained from position-sensing gages be used because of the possible complications arising from entrapped debris, thermal expansion due to frictional heating, hydrodynamic lift,

and tribochemical films which can form in the wear interface under certain conditions.)

9.3.1 A cross section of the wear track is the area of the material removed from the original flat surface as viewed on a plane normal to the original surface and to the direction of sliding motion. Cross-sectional profiles may be obtained using a stylus-type instrument or its functional equivalent. On the printed profile made across the wear track, a straight line is drawn between the unworn areas on both sides of the wear scar and the cross-sectional area of the wear groove, below that reference line, is used to compute the wear volume. The cross-sectional area may be determined by planimetry, through the use of computerized digitizing tablet, or by importing the surface trace data directly into a computer program which permits the measurement of areas under profiles. Wear volume of the flat, V_f in mm^3 , is calculated from:

$$V_f = A \times L \quad (5)$$

where:

A = average cross-sectional area of the track, mm^2 , and
 L = length of the stroke, mm.

10. Report

10.1 Report any unusual event such as noise, chattering, or excessive vibration which occurs during the test. Also, report any unusual frictional behavior, as indicated in 10.3.3. Test parameters to be reported should conform with either Procedure A or B. If procedures other than A or B are used, the report should explicitly state so, listing the conditions which are different than those described in 8.5.1.

10.2 Report the following:

10.2.1 Characterization of the ball and flat specimen materials. Information shall be sufficient to establish their source, chemical composition, processing history, surface treatment,

⁵ Whitenton, E. P., and Blau, P. J., “A Comparison of Methods for Determining Wear Volumes and Surface Parameters of Spherically-Tipped Sliders,” *Wear*, Vol 124, 1988, pp. 291–309.

and root-mean-square surface roughness. Commercial designations for materials should be given, if applicable. If a lubricant is used, provide its commercial name or other description, and any other properties needed to identify the source and traceability of the lubricant. Grain size and percent porosity of specimens may be reported, if applicable. If reporting grain size, indicate whether the grain size is nonuniform or duplex. See Test Methods E 112 and E 1181. Additional guidelines for reporting data are found in Guide G 118.

NOTE 4—Quantities which have been measured on the same lot used for fabricating wear test specimens should be distinguished from those obtained on other lots of material (or handbook values) and assumed to apply to the given test specimens. Tests involving proprietary materials are specifically excluded from reporting compositions or processes; however, material lot numbers and as many specific identifiers as possible shall otherwise be provided.

10.2.2 Test Parameters:

10.2.2.1 Applied normal force, N , and ball tip radius, mm.

10.2.2.2 Stroke length, mm.

10.2.2.3 Test duration, s or min:s.

10.2.2.4 Frequency of oscillation, s^{-1} , and type of motion produced by the oscillating drive system; for example, sinusoidal velocity profile, triangular velocity profile, and so forth.

10.2.2.5 Ambient relative humidity, %.

10.2.2.6 Ambient temperature, °C.

10.2.2.7 Whether lubricated or unlubricated.

10.2.3 Results:

10.2.3.1 Wear volume only, not wear rate, is reported because there is no reason to assume that wear occurs at a constant rate throughout the testing period.

10.2.3.2 Wear volume of the ball specimen, if the scar is flat, in mm^3 . See 9.2 for a more detailed discussion of this measurement.

10.2.3.3 Wear volume of the flat specimen, mm^3 . See 9.3 for a more detailed discussion of this measurement.

10.2.3.4 A concise description of the appearance of the wear scars, including the presence of debris deposits or films which form during sliding. Photomicrographs of the scars should be included, if available.

10.2.3.5 When reporting the results of multiple tests, indicate the number of replicates per material and condition and the average wear volumes for ball and flat specimens. Report the standard deviation.

10.3 Reporting Optional:

10.3.1 Report the computed value of the maximum elastic contact stress (S_c), as calculated by the method developed by Hertz. The following equation may be used:

$$S_c = 0.918[P/(D^2 E_o^2)]^{1/3} \quad (6)$$

where:

P = applied load, N, and

D = diameter of the sphere m.

E_o is obtained from:

$$E_o = \{[(1 - \nu_1^2)/E_1] + [(1 - \nu_2^2)/E_2]\} \quad (7)$$

where:

$E_{1,2}$ = elastic moduli (Young's moduli) of the two solids in contact, Pa , and

$\nu_{1,2}$ = Poisson's ratios (dimensionless) of the two materials, respectively.

If the calculated contact stress exceeds the hardness of either material, there will be permanent plastic deformation and elastic conditions do not apply.

10.3.2 Photomicrographs or surface analysis data for the wear scars on the ball and flat specimens.

10.3.3 A description of the frictional behavior observed during the test. Kinetic friction coefficient can be calculated from:

$$\mu_k = F/P \quad (8)$$

where:

μ_k = kinetic friction coefficient,

F = nominal, measured friction force during sliding, N, and

P = applied load (normal force), N.

10.3.4 On some machines, root-mean-square friction force is available as an instrumentation output. The test report should clearly indicate the manner in which friction force was obtained. Further guidance in measuring and reporting friction data may be found in Guide G 115.

NOTE 5—Friction force may vary during an experiment due to run-in and other factors. For example, it may start high then experience a transition to a lower value during the test. It is often useful in analyzing test results to note the magnitudes and durations of any observed friction transitions. If friction force remains steady throughout the test or quickly reaches a steady state, one nominal value may be sufficient, otherwise, the type of frictional data reported will depend on the overall trends observed during the test. If friction never reaches a steady value, its range of values may be reported with appropriate notations as to its behavior.

11. Precision and Bias

11.1 *Precision*—The precision of wear determinations is dependent on the wear characteristics of the material under the imposed testing conditions. Some materials wear evenly so as to produce clearly defined wear scars, and wear dimensions can be measured with a higher degree of precision than for certain other materials which wear in an uneven manner and whose wear scars cannot be delineated as clearly.

11.2 *Repeatability and Reproducibility*—Procedure A was used in the same laboratory to conduct eight tests of silicon nitride sliding on silicon nitride. The coefficient of variation of the wear volume of the flat specimens was 34.7 %. The coefficient of variation for the friction coefficient in the same tests was 1.8 %. The same specimen materials were tested in five laboratories using Procedure B with mineral oil lubrication. The coefficient of variation for the wear volume of the flat specimens within-laboratory was ± 23.7 %. Reproducibility was reflected in a between-laboratory coefficient of variation of ± 48.6 %. For the friction coefficient, the within-laboratory coefficient of variation was ± 2.64 % and the between-laboratory coefficient of variation was ± 5.29 %. Appendix X1 provides examples of the repeatability and reproducibility of Procedures A and B when applied to tests of silicon nitride ceramics. These numerical values for repeatability and reproducibility do not necessarily represent those quantities which would be obtained if other material combinations were tested

under Procedures A and B. Since the repeatability and reproducibility of wear and friction data are material-dependent, a general statement for Procedures A or B cannot be made.

11.3 *Bias*—Since there is no accepted reference material for determining the bias of the procedures in this wear testing method, there is no basis upon which to determine the bias.

12. Discussion

12.1 Wear testing involves careful attention to specimen preparation, characterization, cleaning, and test procedures. Contact geometry, normal force, type of motion, temperature, surface finish, and ambient environment should be as close as possible to that of a chosen application if wear screening is to provide meaningful results.

12.2 Wear rate can change during the course of a test or during the course of the life of a wear part. Run-in wear rates can exceed steady-state wear rates, and catastrophic transitions in wear rate can occur to end the useful life of a component. In this test method, wear is reported only as the total volume lost after a set period of sliding. This avoids making the assumption that the wear rate was constant during the test. One indirect indication that wear rate may be changing is a significant change in the nominal level of the friction force during a test. To determine the change in wear rate with test duration, interrupted tests with periodic wear volume assessments may be made. However, the replacement of the specimens in the

machine to continue testing may not produce identical contact conditions to those when the test was interrupted.

12.3 Moisture in the air (humidity) has been shown to affect both friction and wear of ceramics, metals, and polymers. The range of relative humidities over which pronounced changes in tribological behavior occur may be relatively short and it may vary between materials. Therefore, restricting testing to a $50 \pm 10\%$ band of relative humidity does not necessarily ensure that the friction or wear at each end of the band will be the same. It is better to hold the humidity variation for a series of tests to $\pm 5\%$ or less, if possible. Construction of a controlled-humidity enclosure around the testing fixtures is the best approach but is not required to meet the requirements of this test method. Testing on days with similar humidity readings is a less-desirable alternative.

12.4 Unlike material combinations may wear at different rates depending on which material is the ball specimen and which is the flat specimen. The ball specimen experiences nominally constant contact, whereas the flat specimen surface experiences a changing state of stress as the slider passes and may wear by a different set of mechanisms. It should therefore not be assumed that the same relative wear volumes would be obtained if materials for ball and flat specimens were reversed.

13. Keywords

13.1 friction testing; lubricated wear; reciprocating wear test; wear of ceramics; wear of metals; wear testing

APPENDIX

(Nonmandatory Information)

X1. RESULTS OF WITHIN-LABORATORY TESTS USING PROCEDURE A WITH SILICON NITRIDE TEST SPECIMENS

TABLE X1.1 Material Descriptors for Pin and Flat Wear Specimens

Item	Pin Specimen	Flat Specimen
Designation	Noralide NBD 200, commercial bearing ball	sintered reaction-bonded silicon nitride (SRBSN)
Source	Cerbec Corp., East Granby, CT	Eaton Corp., Research and Development—Detroit Center, Southfield, MI
Method of production	proprietary	proprietary powder sintering and reaction-bonding process
Surface preparation	9.525-mm diameter ball, AFBMA Grade 5, as-received	surface ground, then diamond-polished to an average finish of $R_a = 0.05 \mu\text{m}$

X1.1 *Procedure A*—A Plint Model TE-77 testing machine with a Scotch yoke drive mechanism providing a sinusoidal velocity profile was used.⁶ Data for the specimen materials are provided in Table X1.1. Eight replicate tests were performed in one laboratory to evaluate the repeatability of this procedure. The friction coefficient data and flat specimen wear data are given in Table X1.2 and Table X1.3, respectively. It was not

TABLE X1.2 Friction Coefficient Results for Silicon Nitride Specimens Using Procedure A

NOTE 1—Coefficient of variation = $\pm 1.8\%$; 95 % confidence limits = 0.04.

Test Number	Friction Coefficient, μ	Deviation from Average, μ
1	0.800	-0.005
2	0.800	-0.005
3	0.803	-0.002
4	0.808	0.003
5	0.800	-0.005
6	0.781	-0.024
7	0.820	0.015
8	0.828	0.023
Average = 0.81		Standard Deviation = 0.014

possible to report the wear of the ball specimens under the provisions of this test method since both ball and flat specimens wore.

X1.2 Results of Interlaboratory Tests Using Procedure B with Silicon Nitride Specimens:

X1.2.1 Five laboratories participated. All laboratories used a Plint Model TE-77 testing machine with a Scotch yoke drive

⁶ Model TE-77 High Frequency Friction Machine, Phoenix Tribology Ltd., UK.

TABLE X1.3 Wear Volume Results for Silicon Nitride Specimens Using Procedure A

NOTE 1—Coefficient of variation = $\pm 34.7\%$; 95 % confidence limits = 0.53.

Test Number	Flat Wear Volume, mm ³	Deviation from Average, mm ³
1	0.746	0.203
2	0.611	0.068
3	0.507	-0.036
4	0.635	0.092
5	0.293	-0.250
6	0.229	-0.314
7	0.619	0.076
8	0.707	0.164
Average = 0.543		Standard Deviation = 0.189

mechanism providing a sinusoidal velocity profile. The specimen materials were the same as those described in Table X1.1. Mineral oil (J. T. Baker Company, U.S.P. grade, with Vitamin E added as a stabilizer, viscosity by Brookfield viscometer was 140 cP, and the flash point was 215°C) was used as the lubricant. Two flat specimens and one ball specimen were supplied to each laboratory. Two wear tests were performed on

each flat specimen using a fresh area of the ball specimen for each test; therefore, four tests were conducted. Nominal friction coefficient values were obtained from chart recordings of the root-mean-square friction force. A spread sheet computer software package designed for Guide G 117 was used to process test data on steady-state friction coefficient and the computed wear volumes flat specimens from stylus traces of the wear grooves (see 9.3). The ball wear volume was not reported because the scars on the balls were not flat.

X1.2.2 Results are summarized in Table X1.4 and Table X1.5. As is often the case for wear tests, the within-laboratory repeatability is better than the between-laboratory reproducibility. The friction coefficient data (Table X1.4) exhibited less variation than the wear volume data (Table X1.5). The latter quantity requires more steps in order to obtain a final numerical value so that the potential for compounding measurement uncertainties, rounding errors, and calculation errors is greater.

X1.2.3 These data illustrate the variability of Procedure B with a given set of ceramic materials and a single lubricant, and should not be used to estimate the variability to be expected for other materials or lubricants.

TABLE X1.4 Friction Coefficients for Silicon Nitride Specimens Using Procedure B

NOTE 1—Coefficient of variation (%): within laboratory—2.635; between laboratory—5.285. 95 % limit: within laboratory—0.011; between laboratory—0.023.

Laboratory Number	Number of Replicates	Average, μ	Standard Deviation, μ	Deviation from Average
1	4	0.163	0.002	0.008
2	4	0.155	0.002	0.000
3	4	0.158	0.005	0.003
4	4	0.154	0.005	-0.001
5	4	0.143	0.005	-0.012
Average = 4		Average = 0.155	Within-Laboratory Standard Deviation = 0.004	Between-Laboratory Standard Deviation = 0.008

TABLE X1.5 Flat Specimen Wear Volumes for Silicon Nitride Specimens Using Procedure B

NOTE 1—Coefficient of variation (%): within laboratory— ± 23.708 ; between laboratory— ± 48.632 . 95 % limit: within laboratory—0.00266; between laboratory—0.00546.

Laboratory Number	Number of Replicates	Average, mm^3	Standard Deviation, mm^3	Deviation from Average, mm^3
1	4	0.00338	0.00049	-0.00063
2	4	0.00390	0.00090	-0.00092
3	4	0.00710	0.00132	0.00309
4	4	0.00377	0.00124	-0.00024
5	4	0.00272	0.00044	-0.00129
Average = 4		Average = 0.00401	Within-Laboratory Standard Deviation = 0.00095	Between-Laboratory Standard Deviation = 0.00195

ASTM International takes no position respecting the validity of any patent rights asserted in connection with any item mentioned in this standard. Users of this standard are expressly advised that determination of the validity of any such patent rights, and the risk of infringement of such rights, are entirely their own responsibility.

This standard is subject to revision at any time by the responsible technical committee and must be reviewed every five years and if not revised, either reapproved or withdrawn. Your comments are invited either for revision of this standard or for additional standards and should be addressed to ASTM International Headquarters. Your comments will receive careful consideration at a meeting of the responsible technical committee, which you may attend. If you feel that your comments have not received a fair hearing you should make your views known to the ASTM Committee on Standards, at the address shown below.

This standard is copyrighted by ASTM International, 100 Barr Harbor Drive, PO Box C700, West Conshohocken, PA 19428-2959, United States. Individual reprints (single or multiple copies) of this standard may be obtained by contacting ASTM at the above address or at 610-832-9585 (phone), 610-832-9555 (fax), or service@astm.org (e-mail); or through the ASTM website (www.astm.org).